

WYK 117K 111100011K
WYK 117K 111100011K

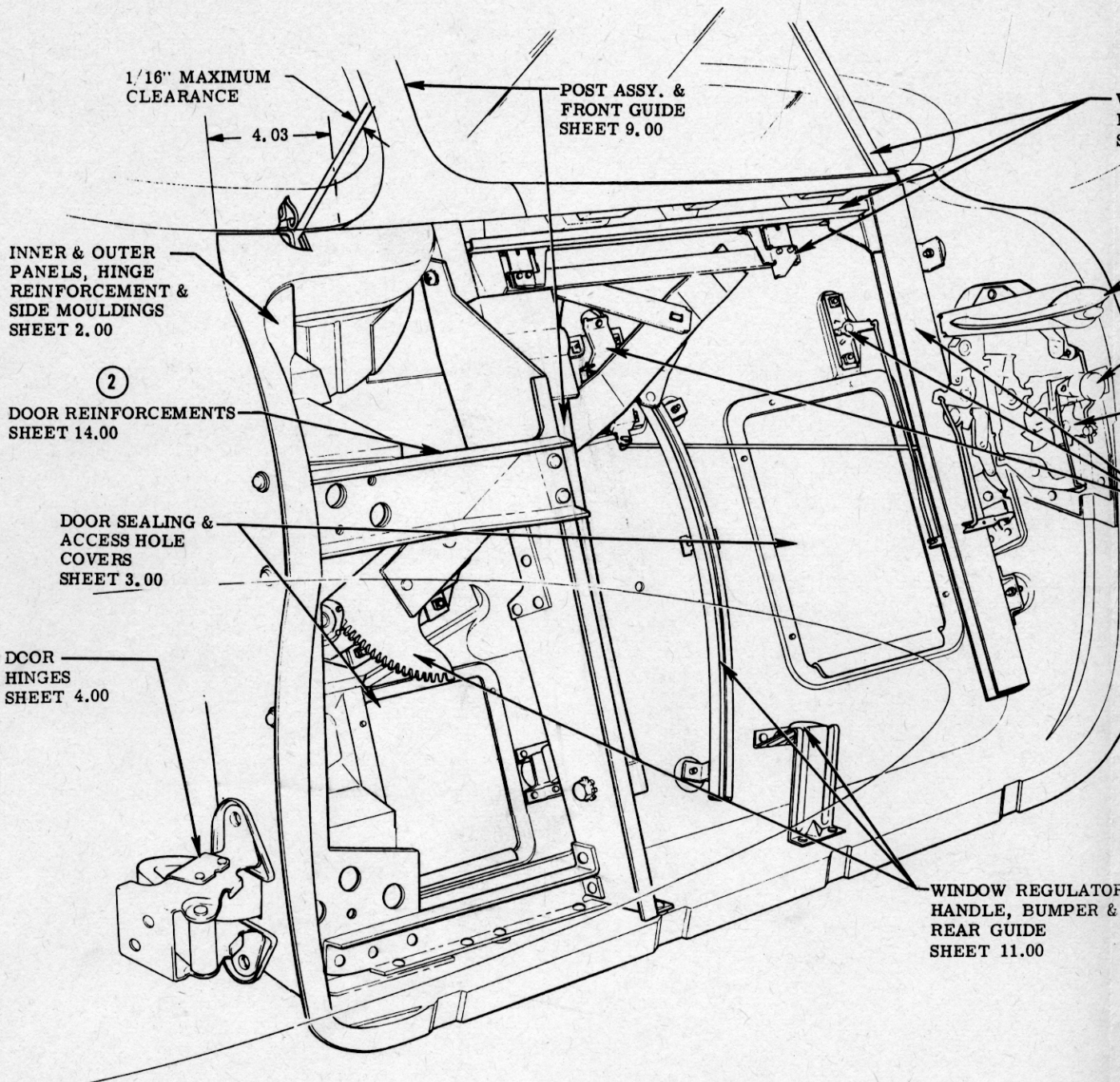

SIDE DOORS



GENERAL MOTORS CORPORATION

WINDOW ASSEMBLY, ADJUSTABLE
BUMPER & UPPER GUIDE RAIL
SHEET 10.00

OUTSIDE DOOR
HANDLE
SHEET 6.00

LOCK CYLINDER
SHEET 7.00

LOCK & STRIKER
SHEET 5.00

REMOTE CONTROLS &
WINDOW REAR RUN
SHEET 8.00

MOULDING &
ARM REST PLATE
SHEET 12.00

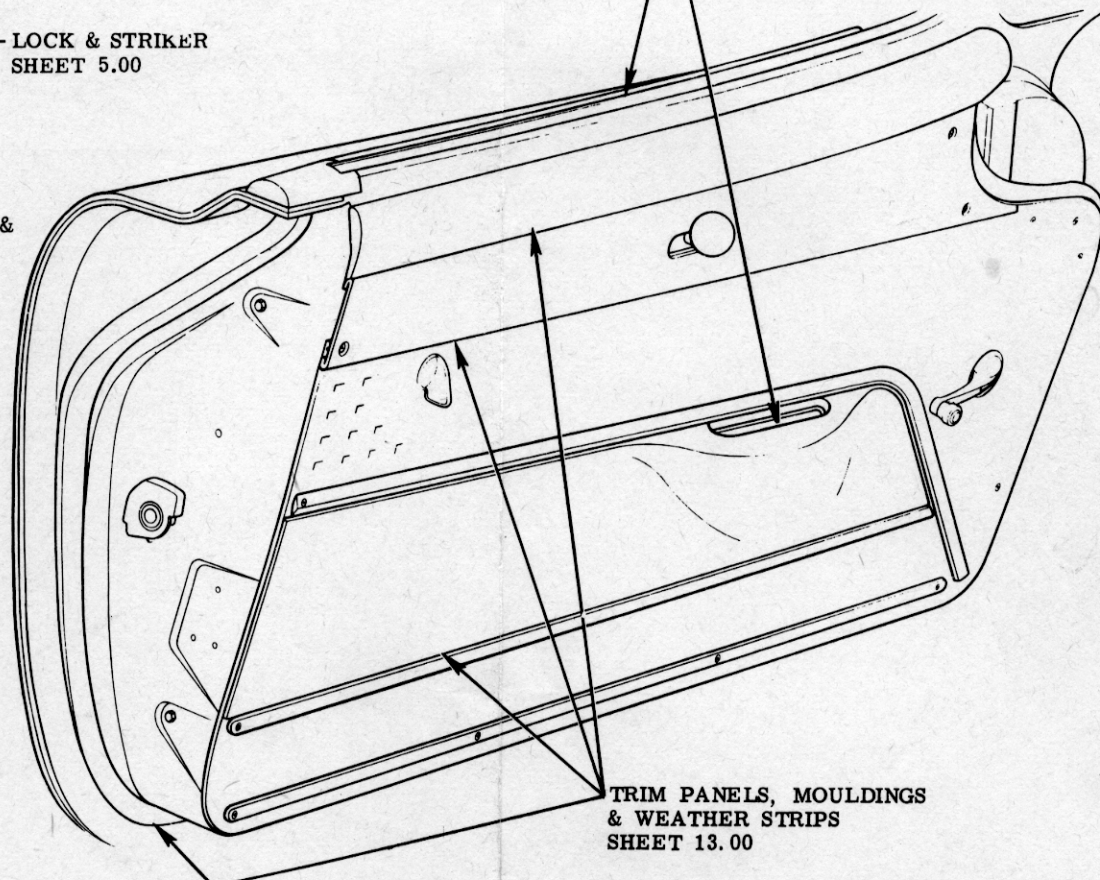

TRIM PANELS, MOULDINGS
& WEATHER STRIPS
SHEET 13.00

							NAME CORVETTE INSTRUCTION MANUAL				
							REF.	DRAWN J. J.	CHECKED L. S.	SECT.	SHEET
6-11-57	2	VIEW REV. & NOTE ADDED	624	V	F				F	1.00	
4-2-56	1	REDRAWN & REVISED 8093-5909-5618			F	DATE 9-15-55	PART No. 3726900				
DATE	SYM.	REVISION RECORD	AUTH.	DR.	CK.						

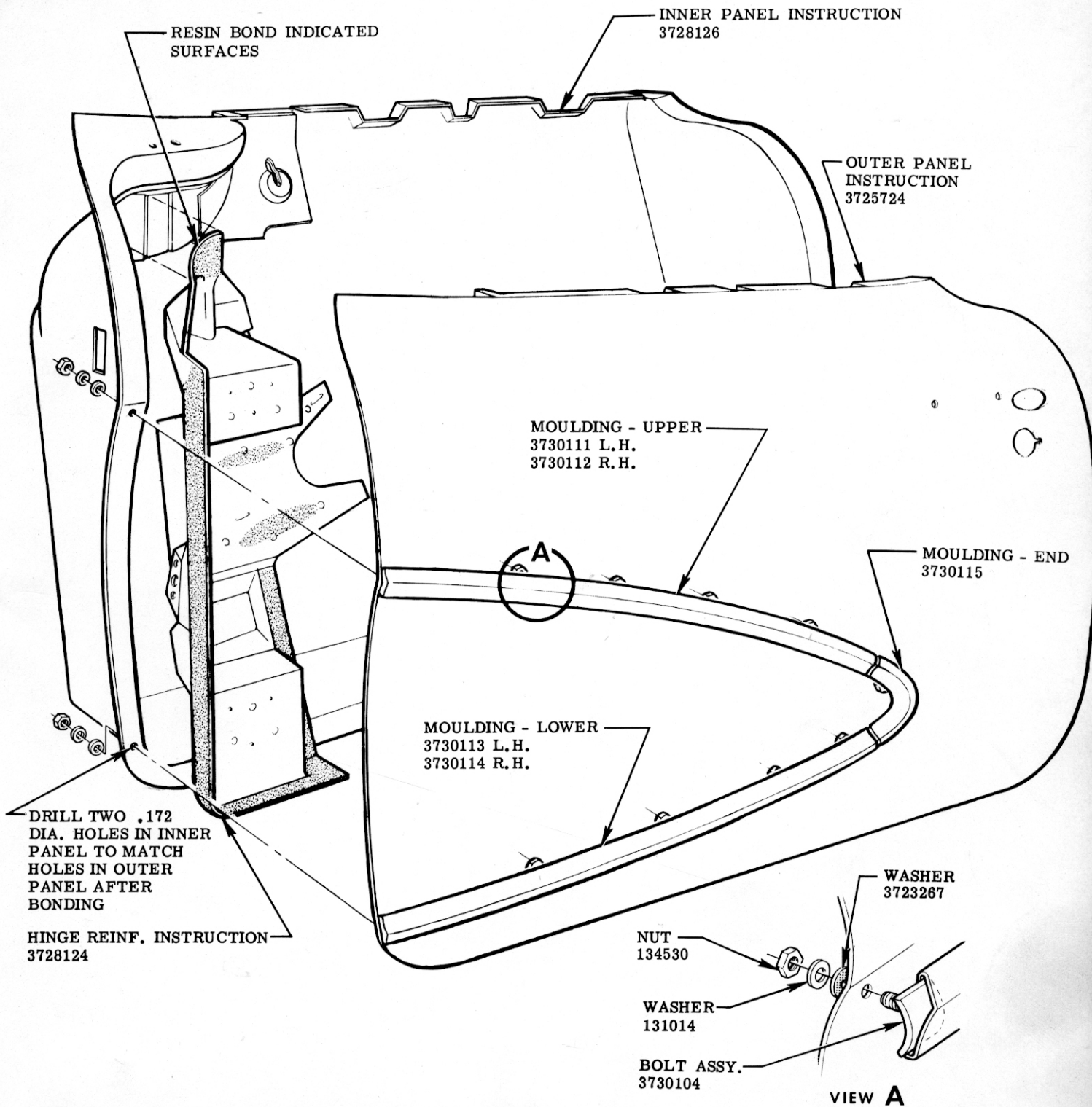

INNER & OUTER PANELS, HINGE REINFORCEMENT & SIDE MOULDINGS

						NAME	CORVETTE INSTRUCTION MANUAL			
						REF.	DRAWN J. J.	CHECKED L. S.	SECT.	SHEET
7-31-56	4	REDRAWN & REV. FOR 57	2416	V	F	DATE	PART No.		F	2.00
DATE	SYM.	REVISION RECORD	AUTH.	DR.	CK.	9-15-55	3726900			

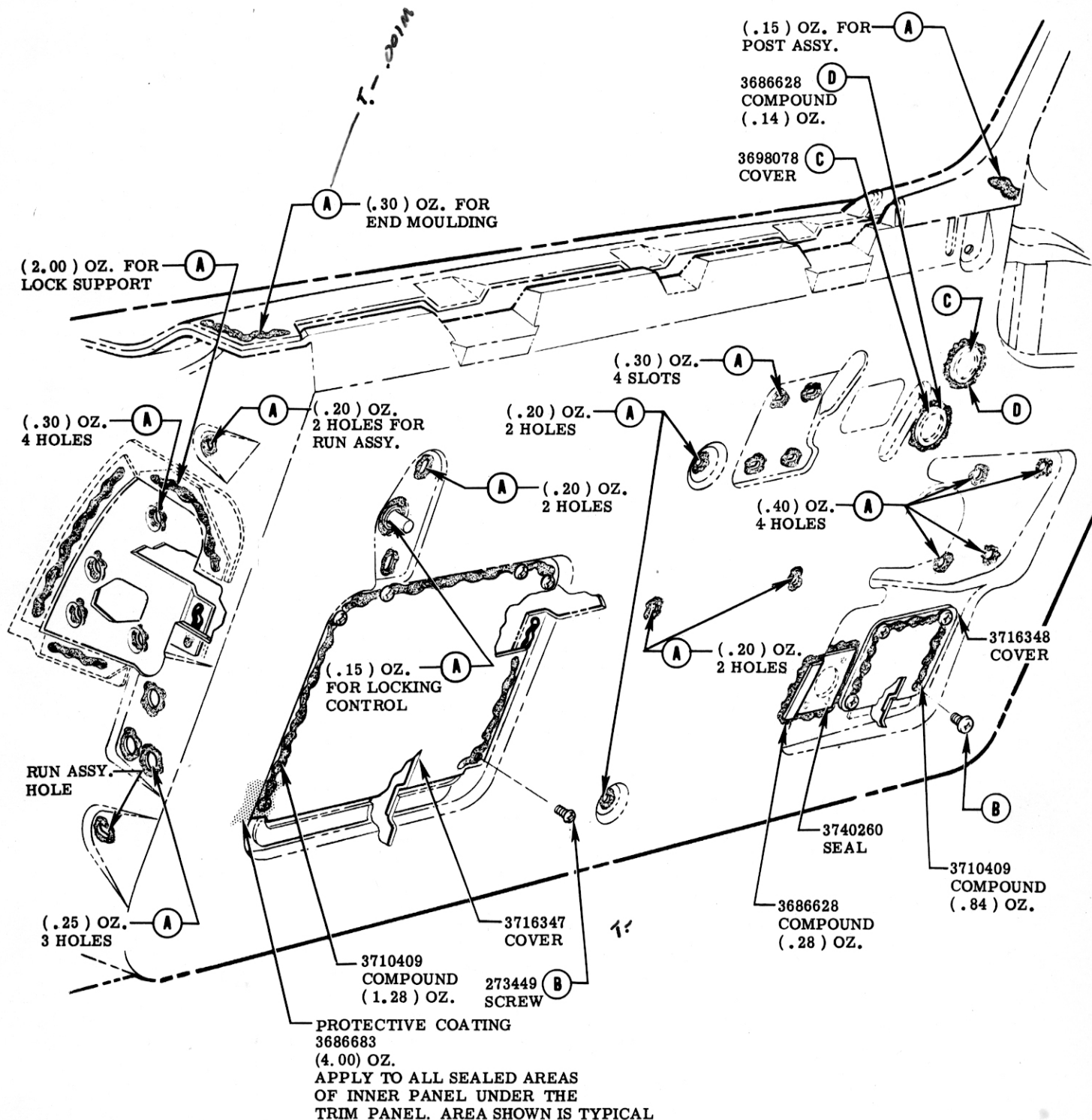

A 466943 COMPOUND - SEALING

DOOR SEALING & ACCESS HOLE COVERS

						NAME CORVETTE INSTRUCTION MANUAL				
						REF.	DRAWN J. J.	CHECKED L. S.	SECT. F	SHEET 3.00
11-13-56	4	REDRAWN & REVISED	4059	V	F	DATE 9-15-55	PART No. 3726900			
DATE	SYM.	REVISION RECORD	AUTH.	DR.	CK.					

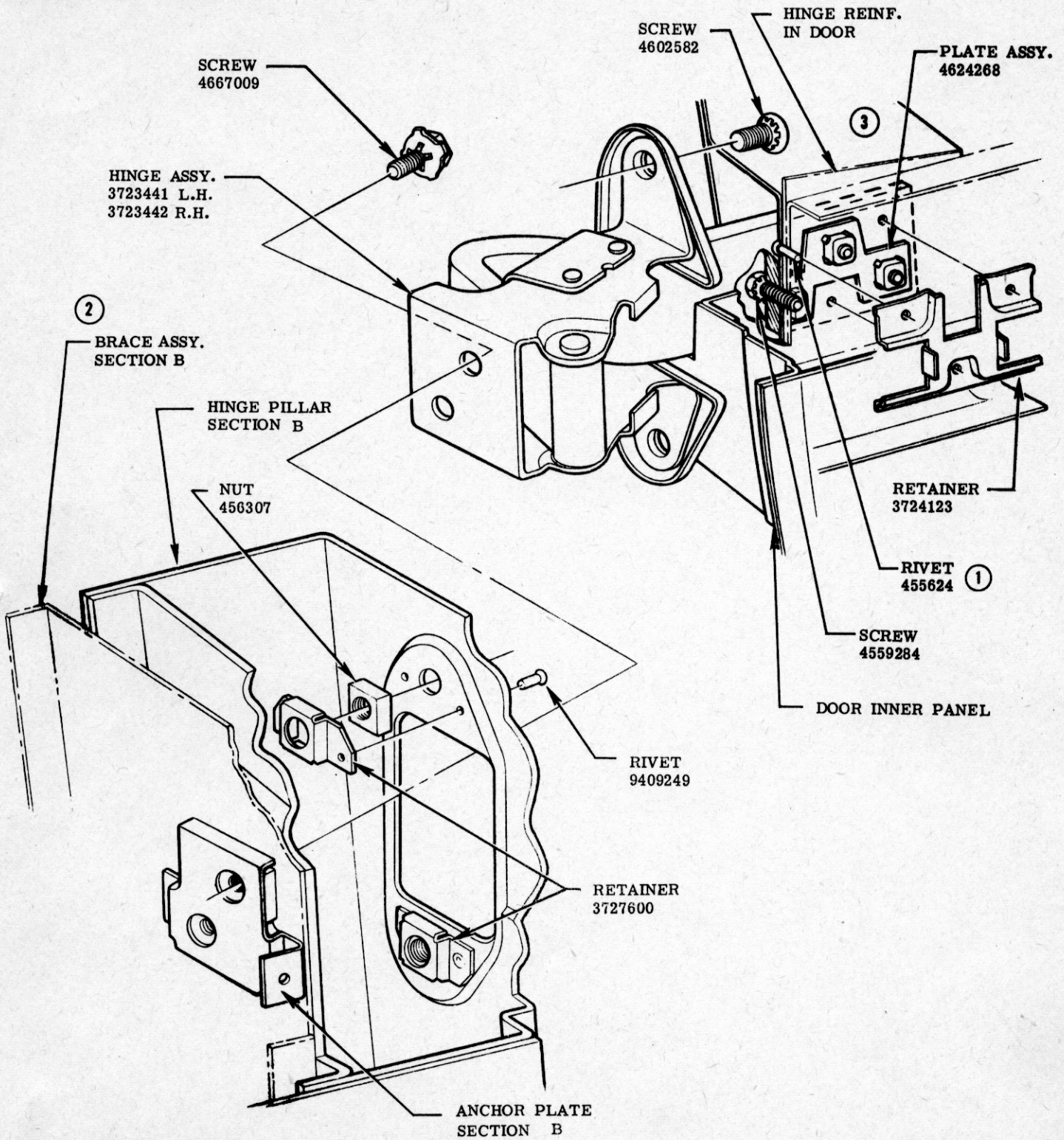

DOOR HINGE

						CORVETTE INSTRUCTION MANUAL				
						NAME				
DATE	SYM.	REVISION RECORD	AUTH.	DR.	CK.	REF.	DRAWN	CHECKED	SECT.	SHEET
6-11-57	3	VIEW REVISED				F	J. J.	L. S.	F	4.00
7-23-56	2	VIEW REV. & NOTE ADDED	624	V						
	1	WAS 9409249 IN ERROR				F				
						DATE	PART No.			
						9-15-55	3726900			

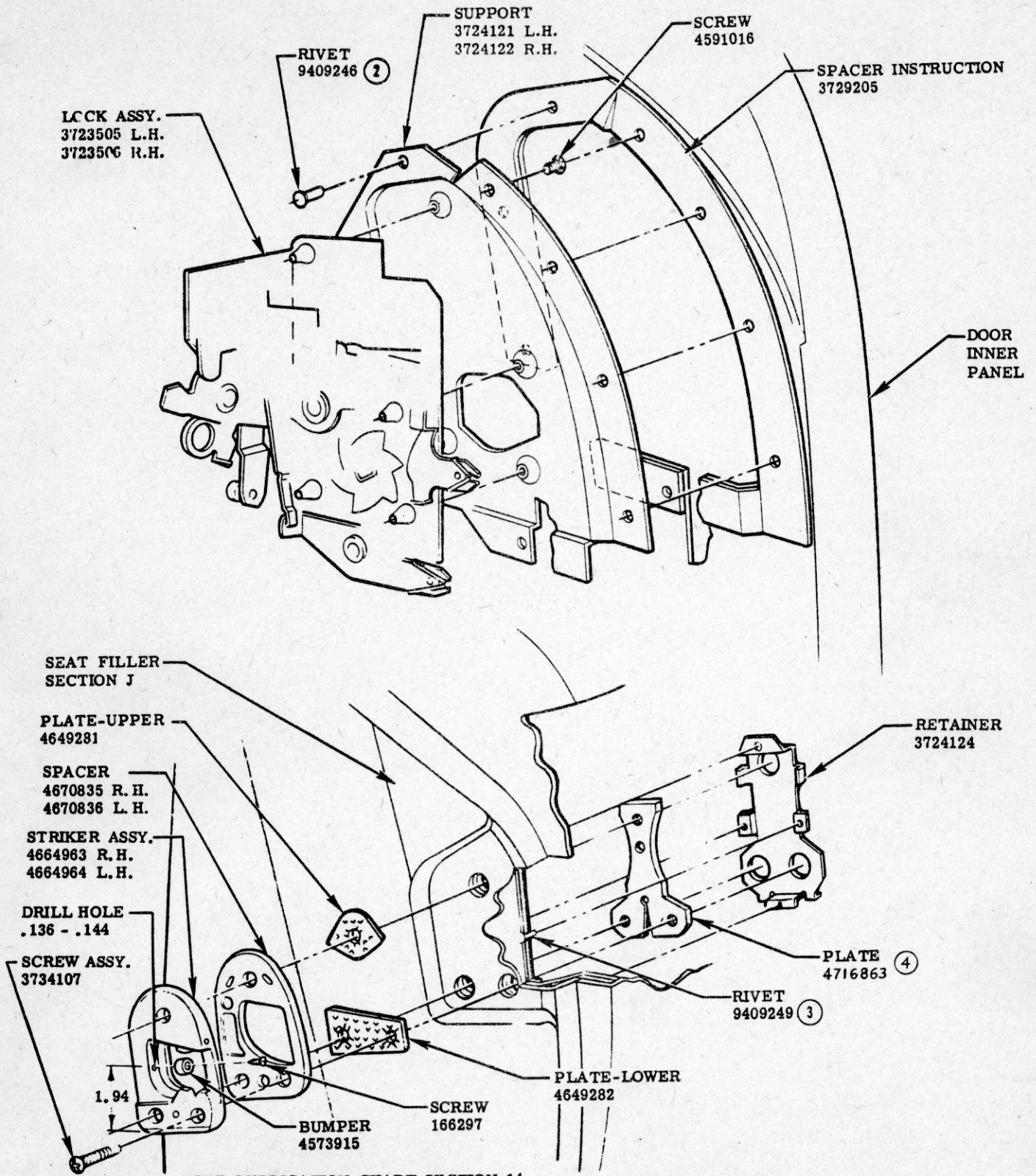

SEE LUBRICATION CHART SECTION 14

LOCK & STRIKER.

6-1-57	4	WAS 4668255	675	F	CORVETTE INSTRUCTION MANUAL				
4-30-57	3	WAS 118089	9797	F	REF.	DRAWN J. J.	CHECKED L. S.	SECT.	SHEET
3-25-57	2	WAS 9409244	528	F				F	5.00
3-12-56	1	REDRAWN & REVISED 7971	6841	V	DATE	PART No.			
		6794	5960		.9-15-55	3726900			
DATE	SYM.	REVISION RECORD	AUTH.	DR.	CK.				

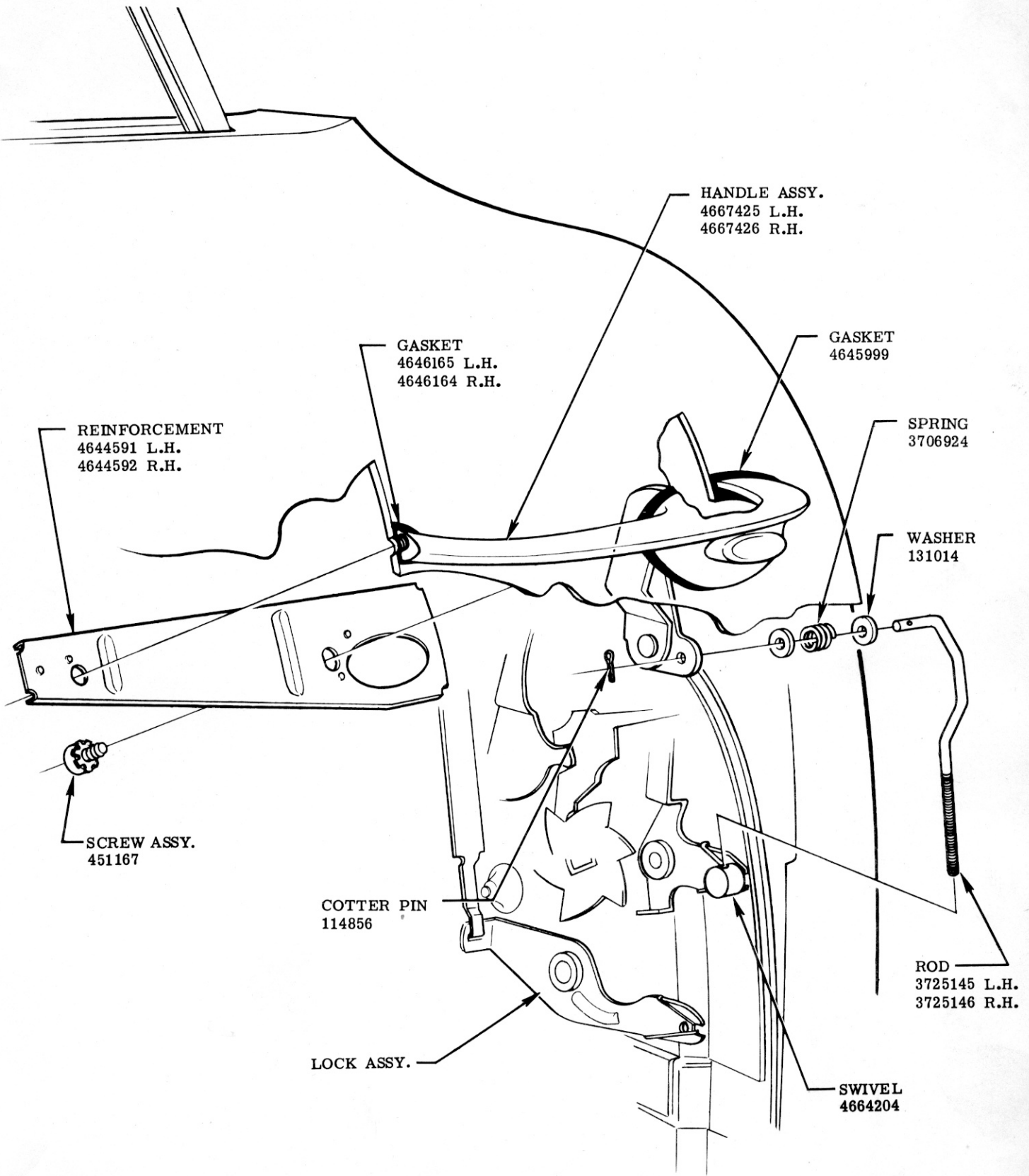

OUTSIDE DOOR HANDLE

					NAME					CORVETTE INSTRUCTION MANUAL				
					REF.	DRAWN		CHECKED		SECT.	SHEET			
						J. J.		L. S.		F	6.00			
					DATE	PART No.								
7-31-56	1	REDRAWN & REVISED FOR 57	2415	F	9-15-55	3726900								
DATE	SYM.	REVISION RECORD	AUTH.	DR.	CK.									

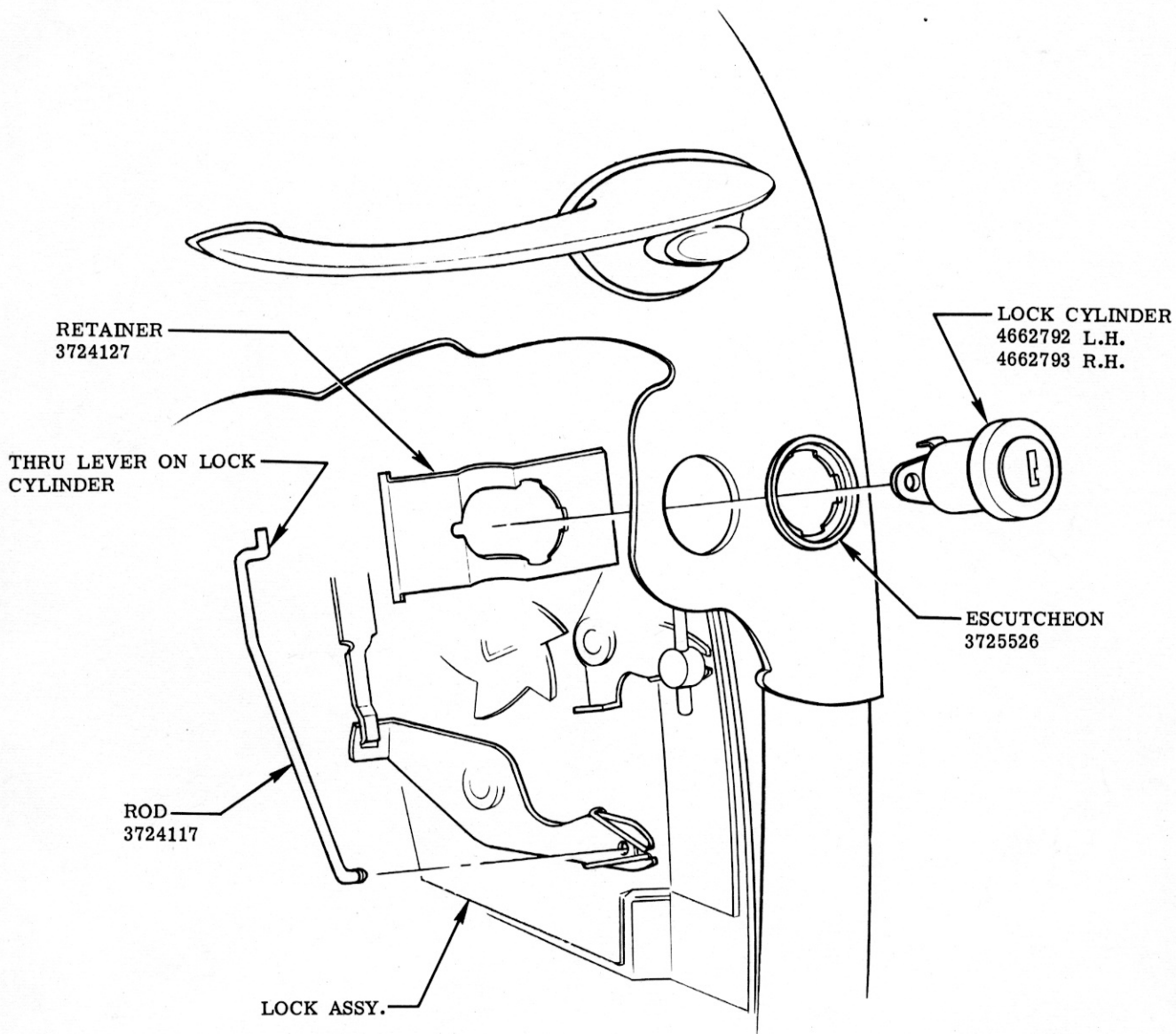

LOCK CYLINDER

						NAME	CORVETTE INSTRUCTION MANUAL			
						REF.	DRAWN R. M.	CHECKED L. S.	SECT.	SHEET
						DATE	PART No.		F	7.00
DATE	SYM.	REVISION RECORD	AUTH.	DR.	CK.	9-15-55	3726900			

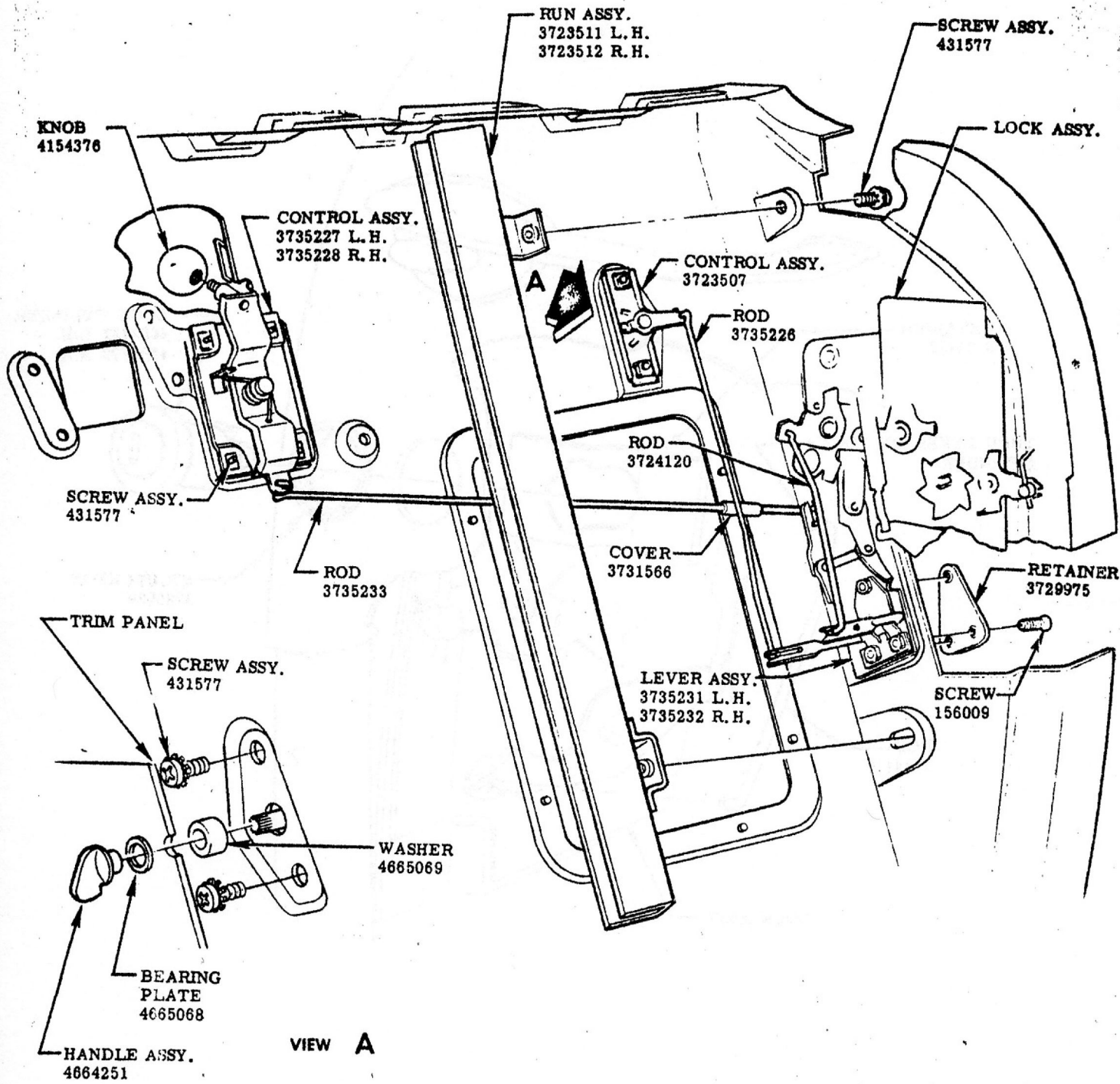

SEE LUBRICATION CHART SECTION 14

REMOTE CONTROLS & WINDOW REAR RUN

				NAME					CORVETTE INSTRUCTION MANUAL				
				REF.	DRAWN		CHECKED		SECT.	SHEET			
4-23-56				1	J. J.		L. S.		F	8.00			
				REDRAWN & REVISED		7990	7816	V	F				
						7607-7583	5960						
DATE	SYM	REVISION RECORD		AUTH	DR	CK	DATE	PART No.		3726900			
							9-15-55						

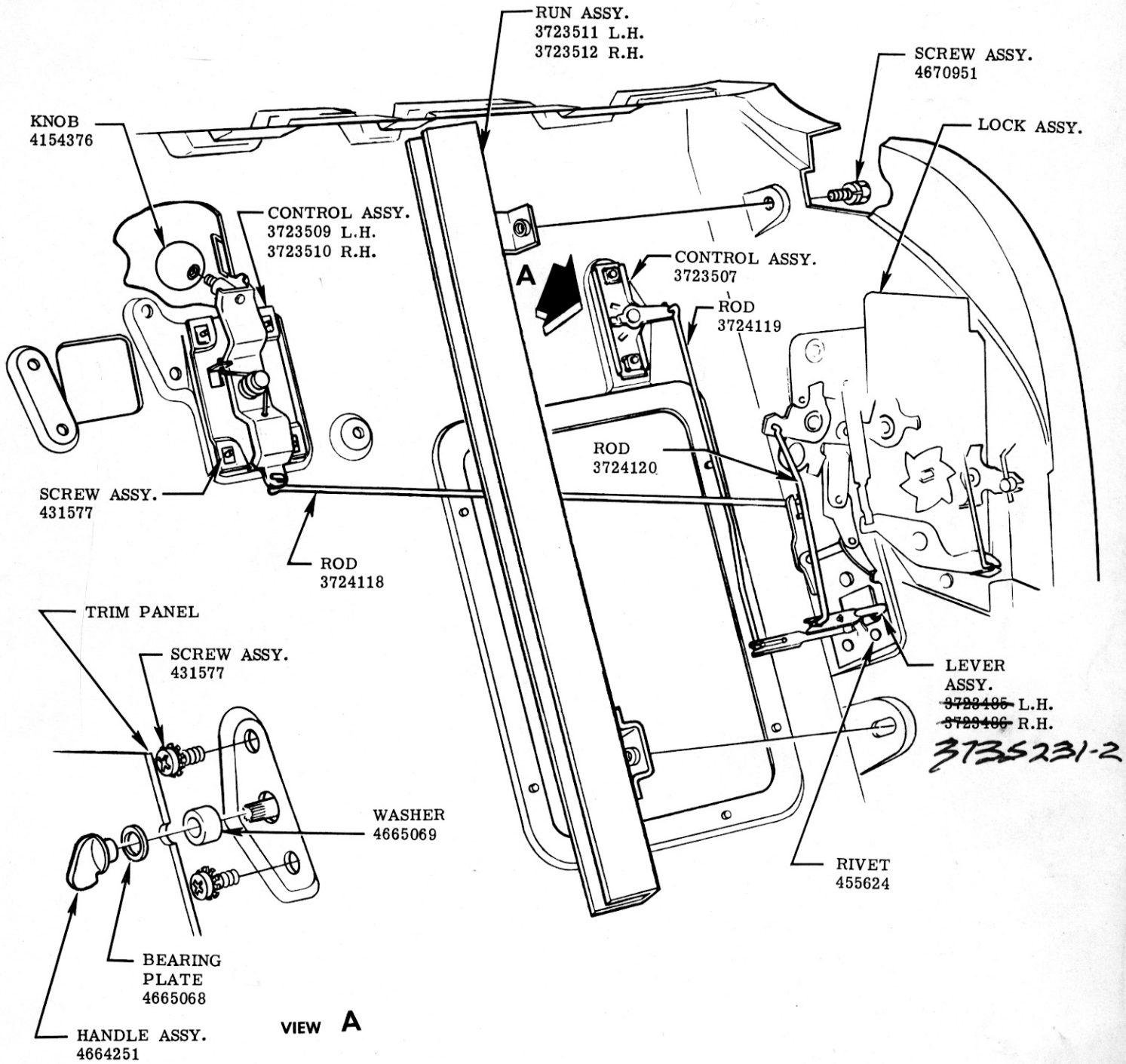

VIEW A

SEE LUBRICATION CHART SECTION 14

REMOTE CONTROLS & WINDOW REAR RUN

						NAME	CORVETTE INSTRUCTION MANUAL			
						REF.	DRAWN J. J.	CHECKED L. S.	SECT.	SHEET
						DATE	PART No.		F	8.00
DATE	SYM.	REVISION RECORD	AUTH.	DR.	CK.	9-15-55	3726900			

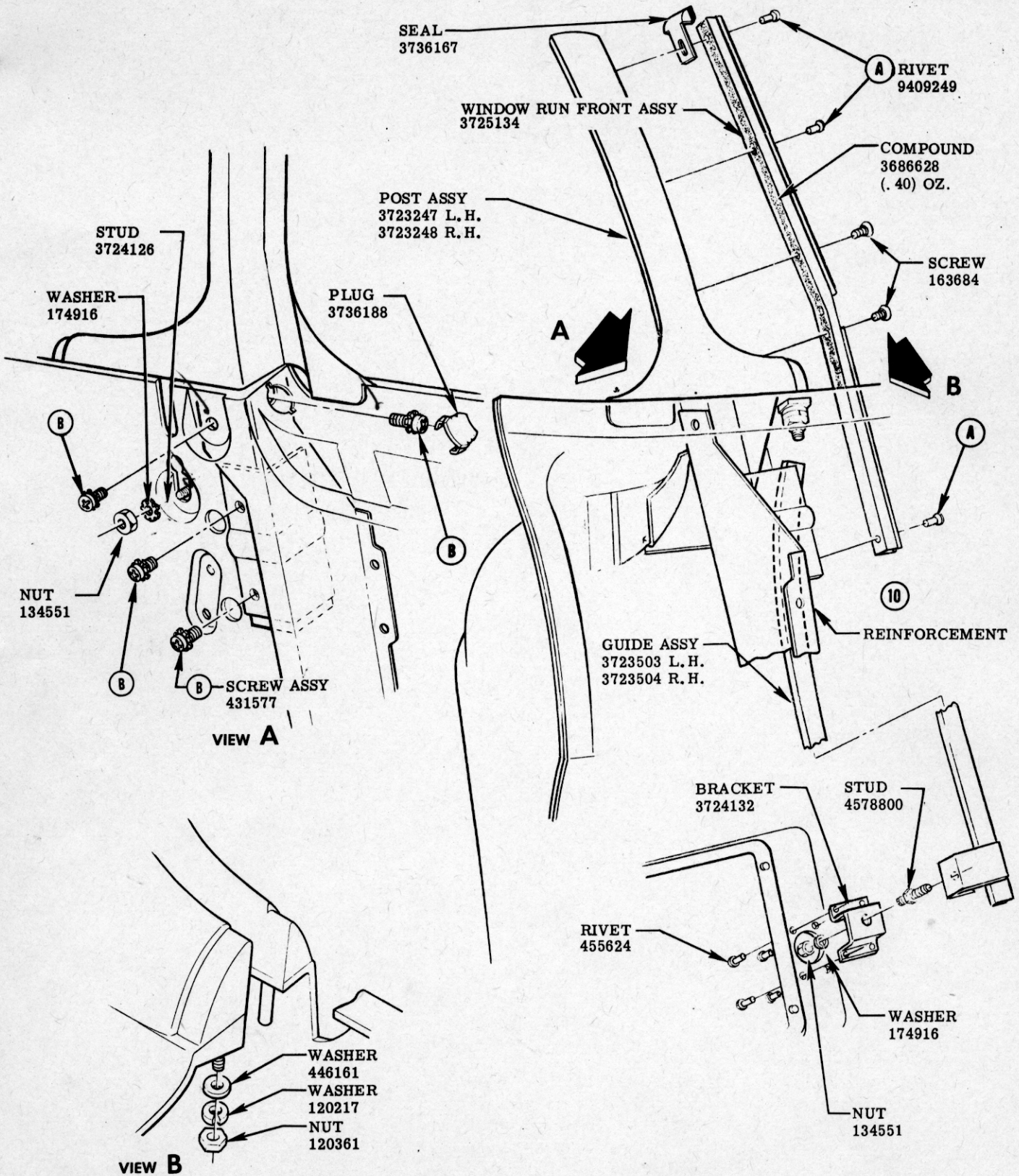

POST ASSEMBLY & FRONT GUIDE

					NAME CORVETTE INSTRUCTION MANUAL				
					REF.	DRAWN J. J.	CHECKED L. S.	SECT. F	SHEET 9.00
6-11-57	9	VIEW REV. & NOTE ADDED	624	V	DATE 9-15-55	PART No. 3726900			
DATE	SYM.	REVISION RECORD	AUTH.	DR.	CK.				

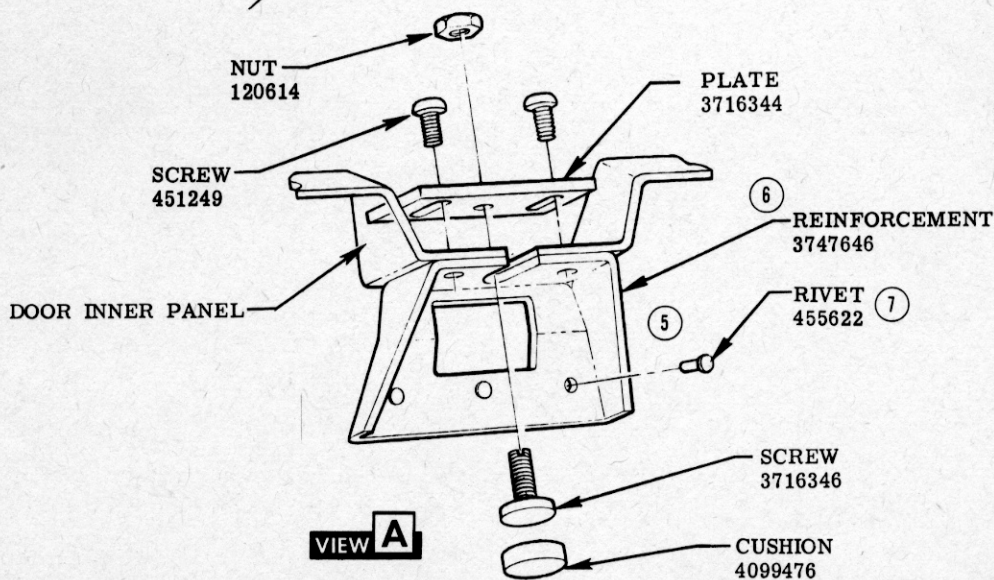
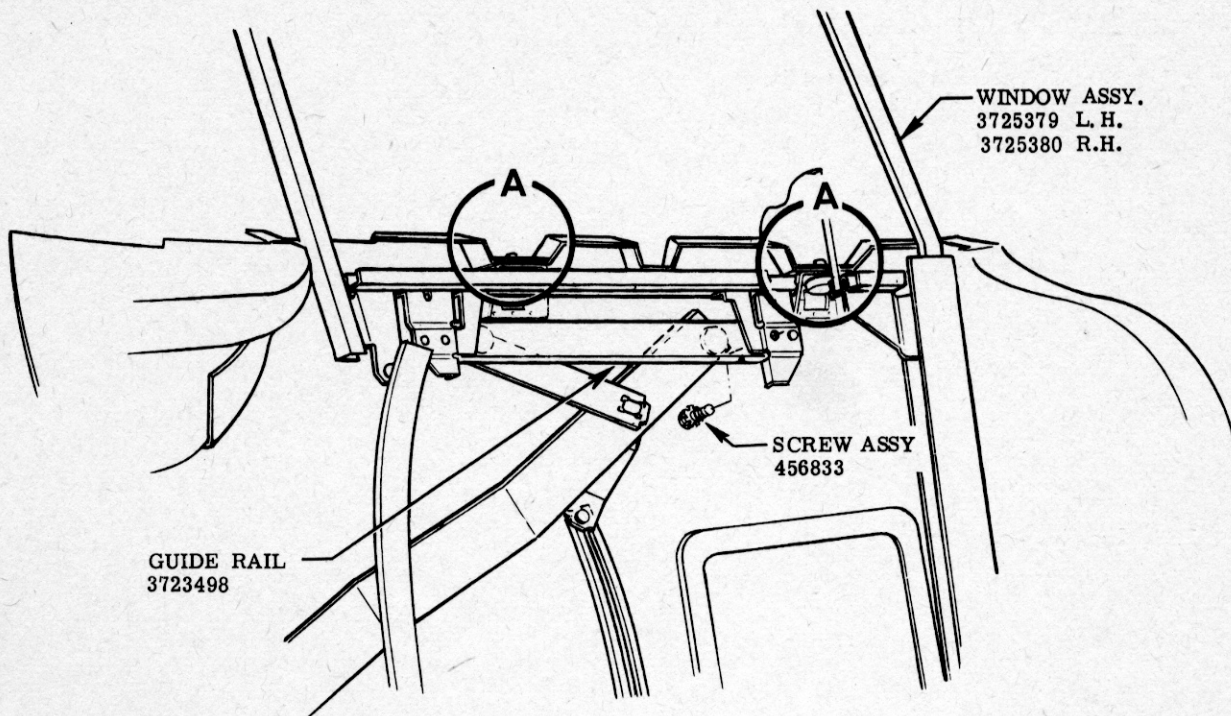

**WINDOW ASSEMBLY, ADJUSTABLE
BUMPER & UPPER GUIDE RAIL.**

						NAME	CORVETTE INSTRUCTION MANUAL			
	7	PART ADDED			F	REF.	DRAWN J. J.	CHECKED L. S.	SECT.	SHEET
	6	WAS 3716345 RETAINER							F	10.00
	5	9409249 RIVET REMOVED								
5-13-57	4	REDRAWN	500	V		DATE	PART No.			
DATE	SYM.	REVISION RECORD	AUTH.	DR.	CK.	9-15-55	3726900			

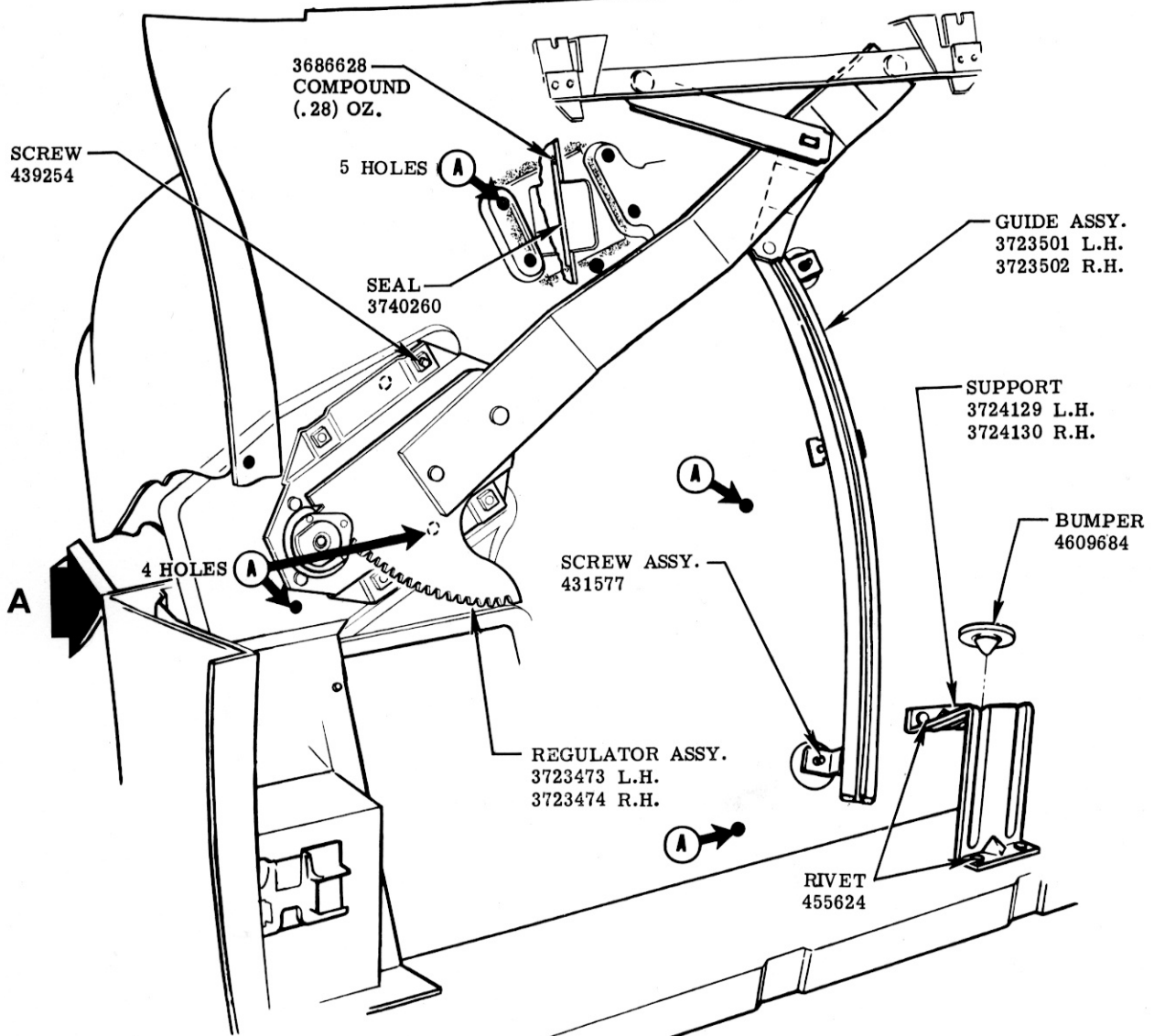
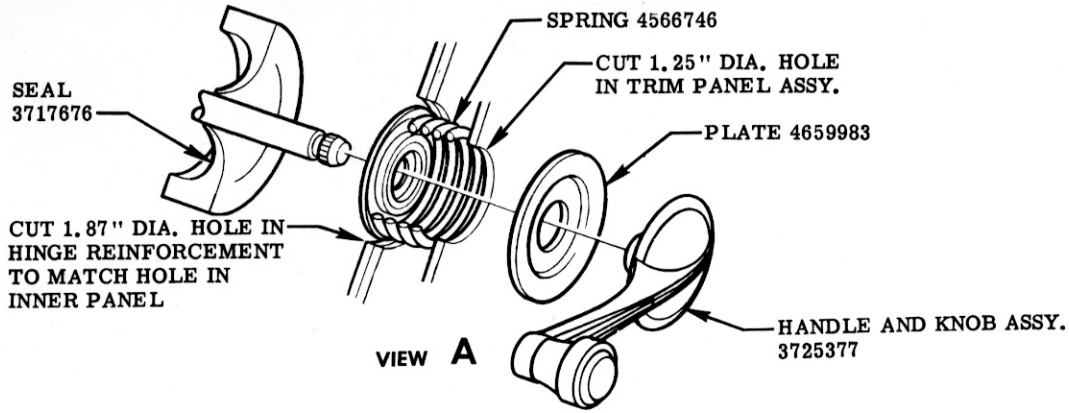

(A) → = FILL ELECTRIC WINDOW REGULATOR HOLES INDICATED BY THIS SYMBOL WITH RESIN

WINDOW REGULATOR, BUMPER & REAR GUIDE

						CORVETTE INSTRUCTION MANUAL				
						NAME	DRAWN	CHECKED	SECT.	SHEET
						REF.	J. J.	L. S.	F	11.00
11-13-56	3	REDRAWN & REVISED	4059	V	F	DATE	PART No.			
DATE	SYM.	REVISION RECORD	AUTH.	DR.	CK.	9-15-55	3726900			

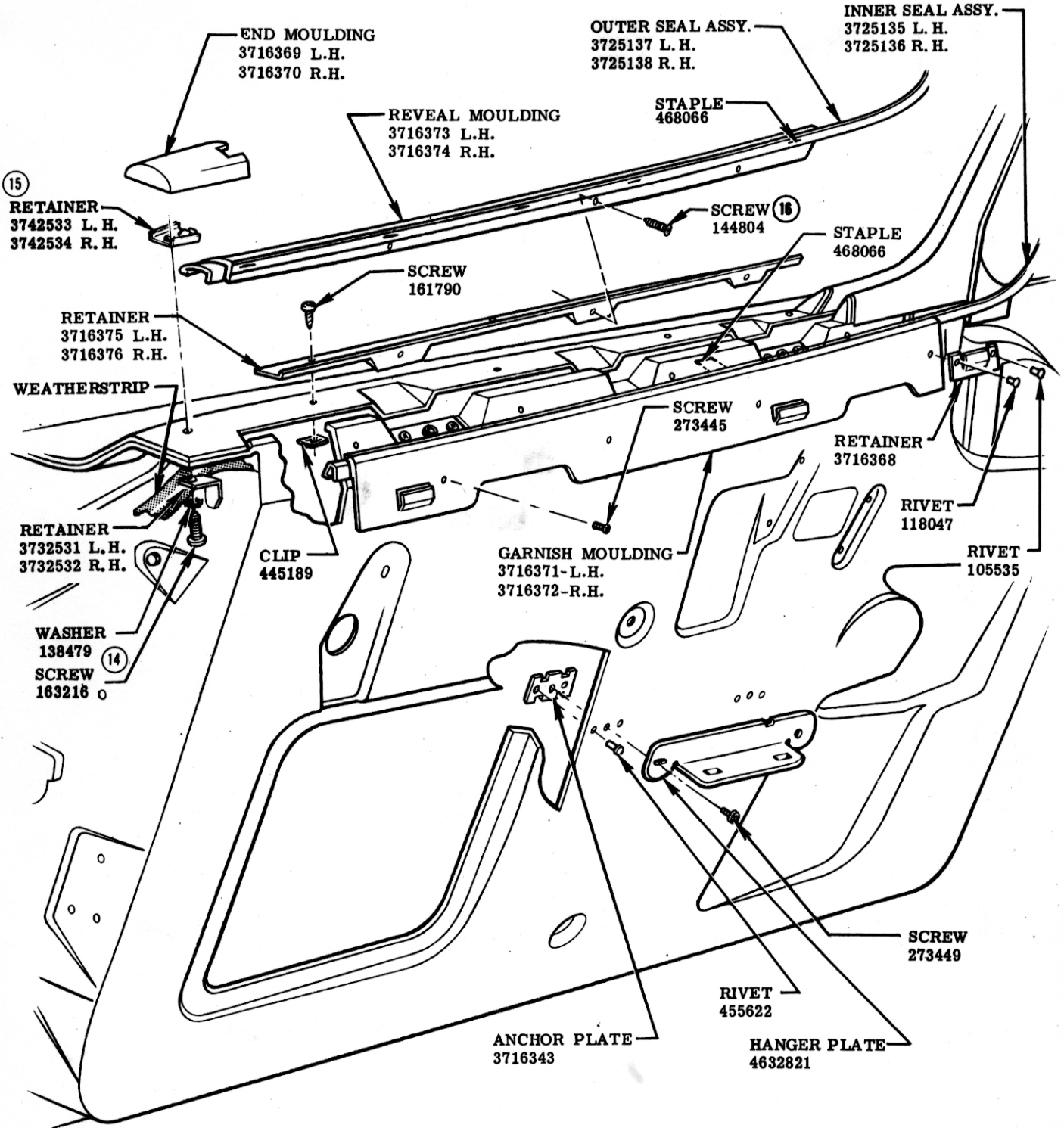

MOULDINGS & ARM REST PLATE

REVISION RECORD					CORVETTE INSTRUCTION MANUAL					
DATE	SYM.	REVISION RECORD	AUTH.	DR.	CK.	NAME	DRAWN	CHECKED	SECT.	SHEET
4-9-57	16	WAS 161790	8762		F		J. J.	L. S.	F	12.00
12-11-56	14	WAS 4574666 -CLIP	119		F					
7-13-56	13	REDRAWN & REVISED FOR 57	2602		F					
						DATE	PART No.			
						9-15-55	3726900			

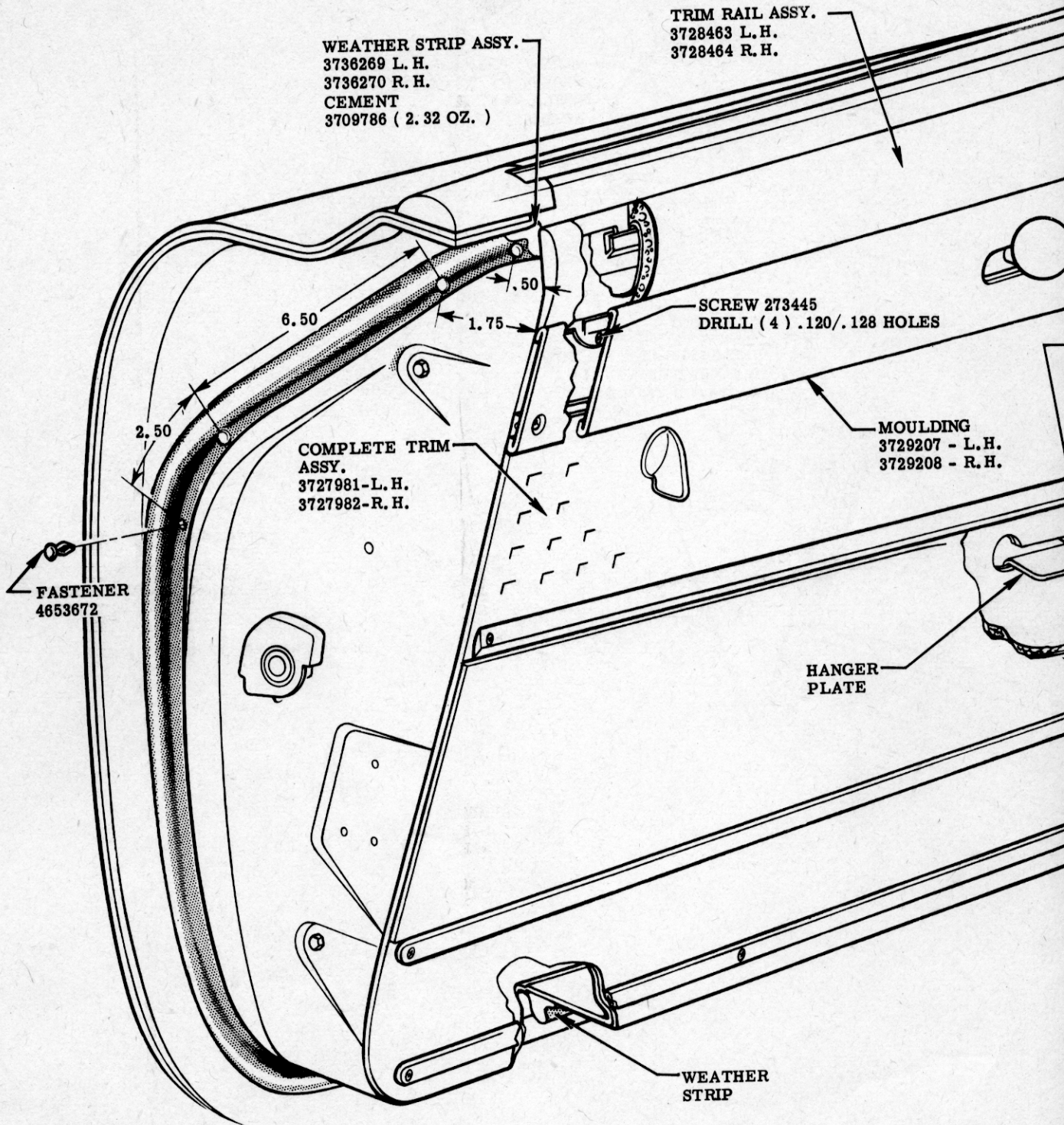

TRIM PANEL, MOULDING & WEATHER STRIPS

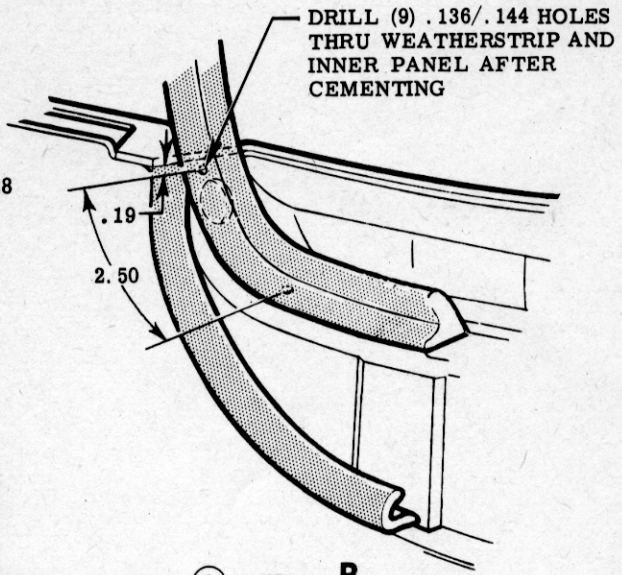
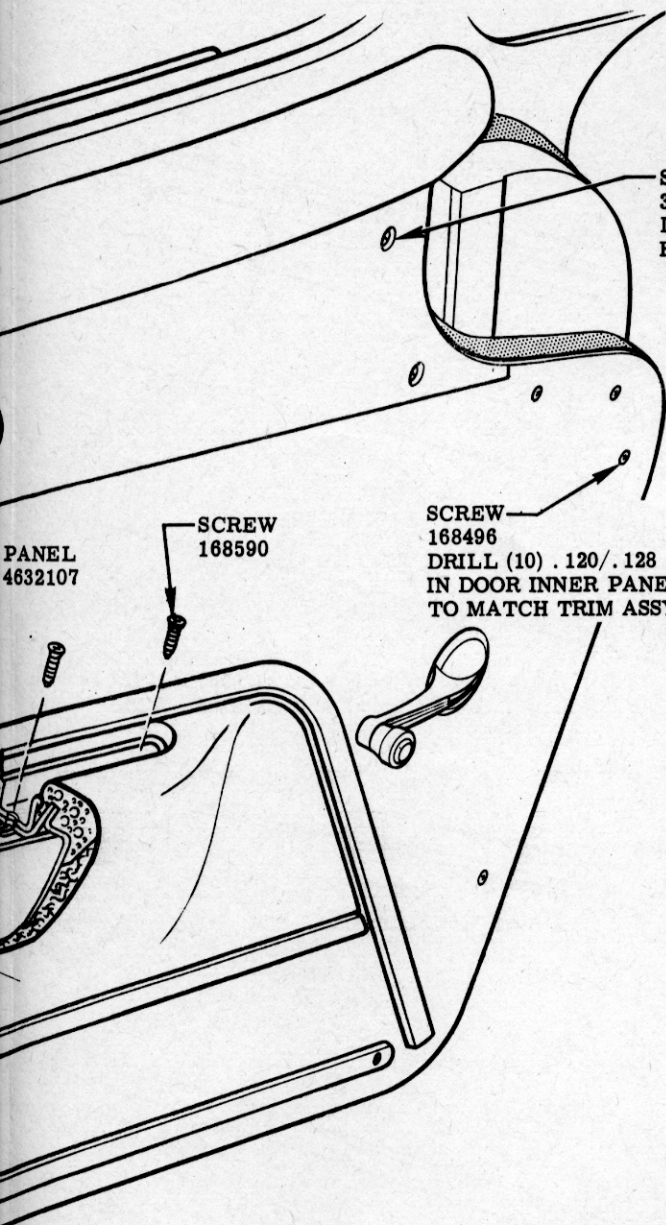

9 VIEW B

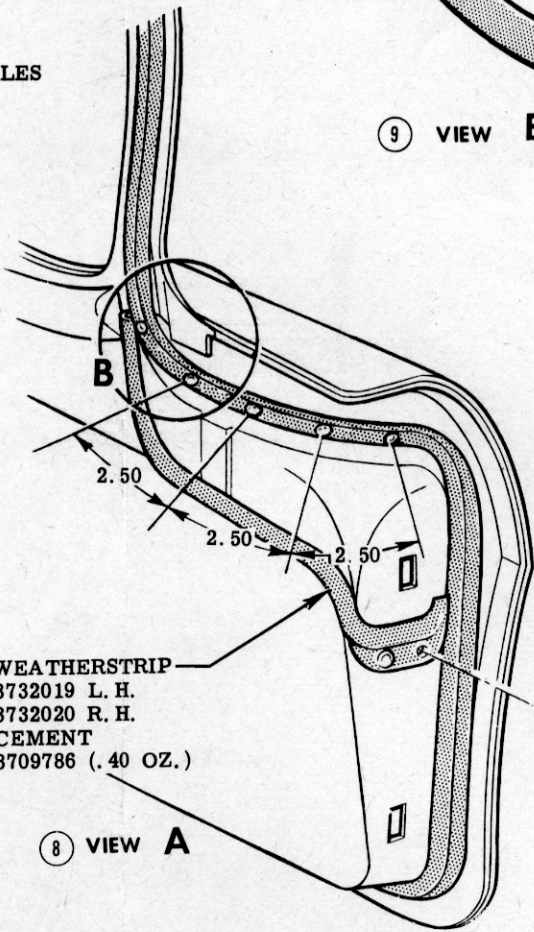

8 VIEW A

					NAME CORVETTE INSTRUCTION MANUAL				
					REF.	DRAWN J. J.	CHECKED L. S.	SECT.	SHEET
					DATE 9-15-55	PART No. 3726900		F	13.00
4-9-57	7	REDRAWN	490						
DATE	SYM.	REVISION RECORD	AUTH.	DR.	CK.				

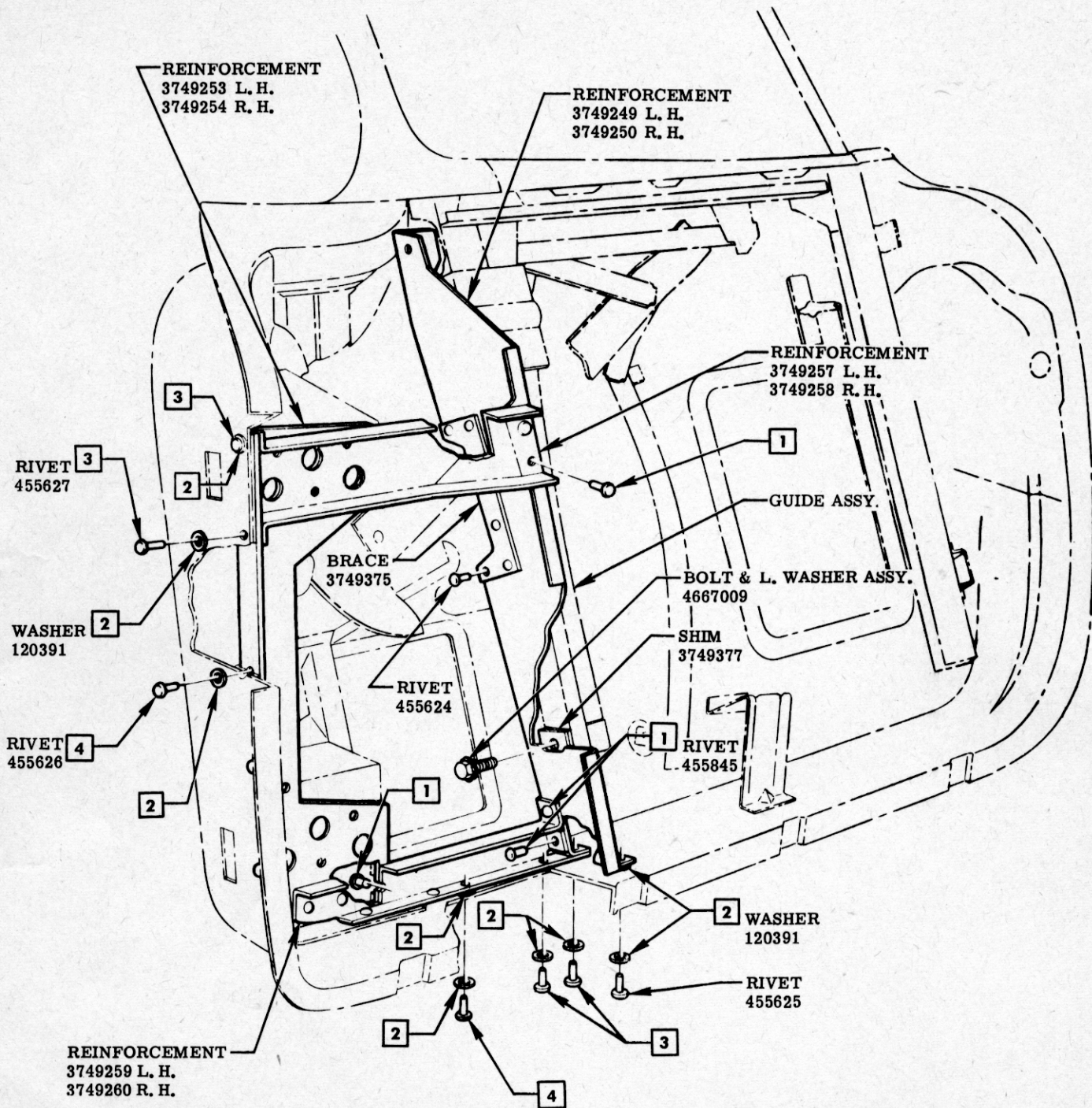

SIDE DOOR REINFORCEMENTS

					NAME CORVETTE INSTRUCTION MANUAL				
					REF. L-48297	DRAWN V	CHECKED F	SECT. F	SHEET 14.00
7-11-57		RELEASED	624		DATE 7-8-57	PART No. 3726900			
DATE	SYM.	REVISION RECORD	AUTH.	DR. CK.					