

A UNDERBODY

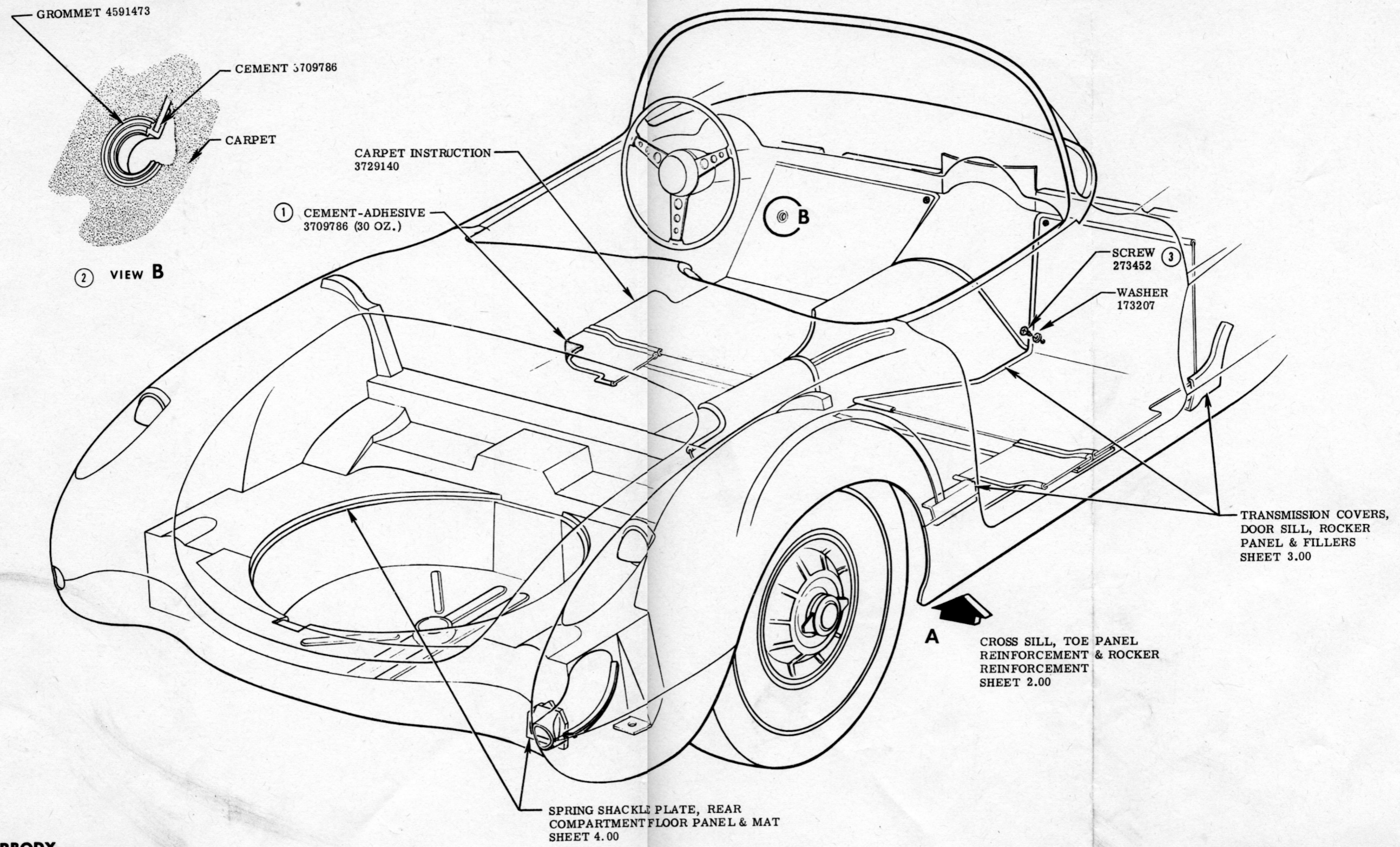

UNDERBODY

						NAME CORVETTE INSTRUCTION MANUAL				
DATE	SYM.	REVISION RECORD	AUTH.	DR.	CK.	REF.	DRAWN O.W.	CHECKED N.D.	SECT.	SHEET
7-16-56	3	WAS 3706732 IN ERROR			F					
	2	VIEW ADDED	5620		F					
1-16-56	1	PART ADDED	7816			DATE	PART No.		A	1.00
						9-15-55	3726900			

Schwarz

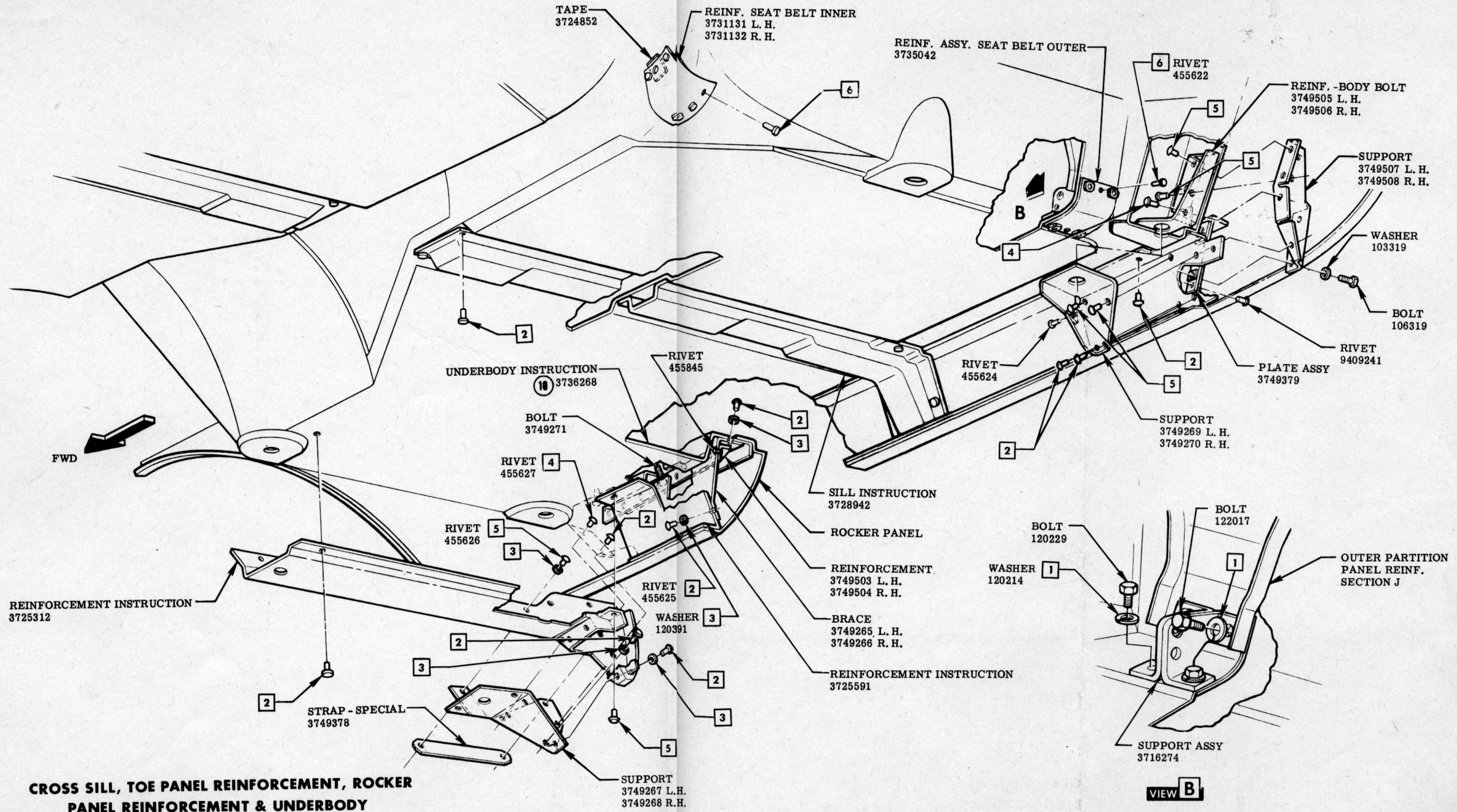

CROSS SILL, TOE PANEL REINFORCEMENT, ROCKER PANEL REINFORCEMENT & UNDERBODY

VIEW IN DIRECTION OF ARROW (A) FROM SHEET 1.00

VIEW B

CORVETTE INSTRUCTION MANUAL										
DATE	SYM.	REVISION RECORD	AUTH.	DR.	CK.	REF.	DRAWN W.S.	CHECKED L.S.	SECT.	SHEET
7-25-57	10	WAS 3728359	2528	V	F					
7-11-57	9	REDRAWN & REVISED	624	F	F					
						DATE 9-15-55	PART No.	3726900	A	2.00

Rouch

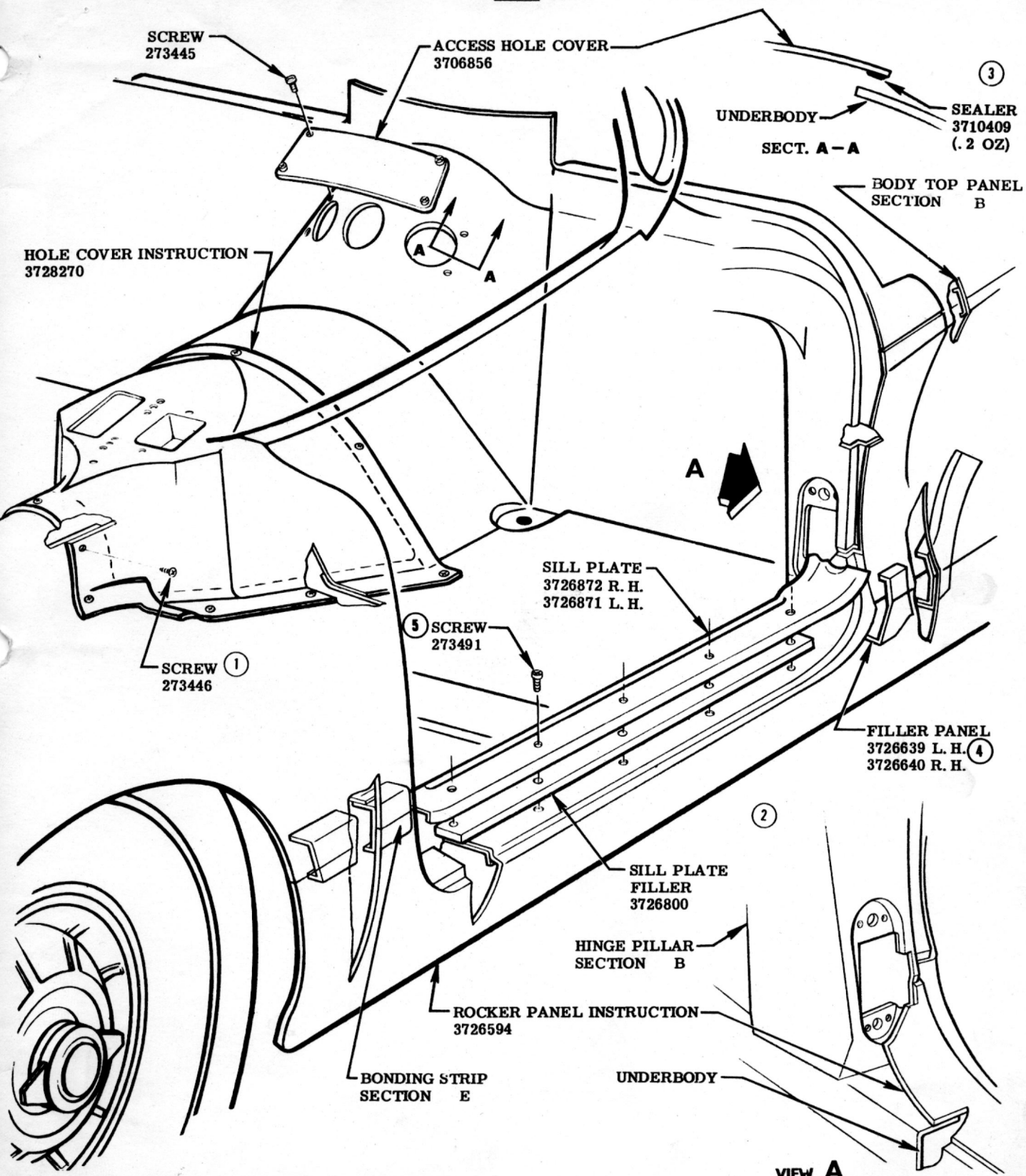

TRANSMISSION COVERS, DOOR SILL, ROCKER PANEL & FILLERS

7-9-56	4	WAS 273490 SCREW	3009		F	CORVETTE INSTRUCTION MANUAL				
3-20-56	3	WAS 3727923 "INSTRUCT."	2413		F	REF.	DRAWN W.M.	CHECKED L.S.	SECT.	SHEET
2-27-56	2	466943-CEMENT REMOVED	8084		F	DATE	PART No.		A	3.00
	1	PART ADDED	7757			9-15-55	3726900			
DATE	SYM.	REVISION RECORD		AUTH.	DR.	CK.				

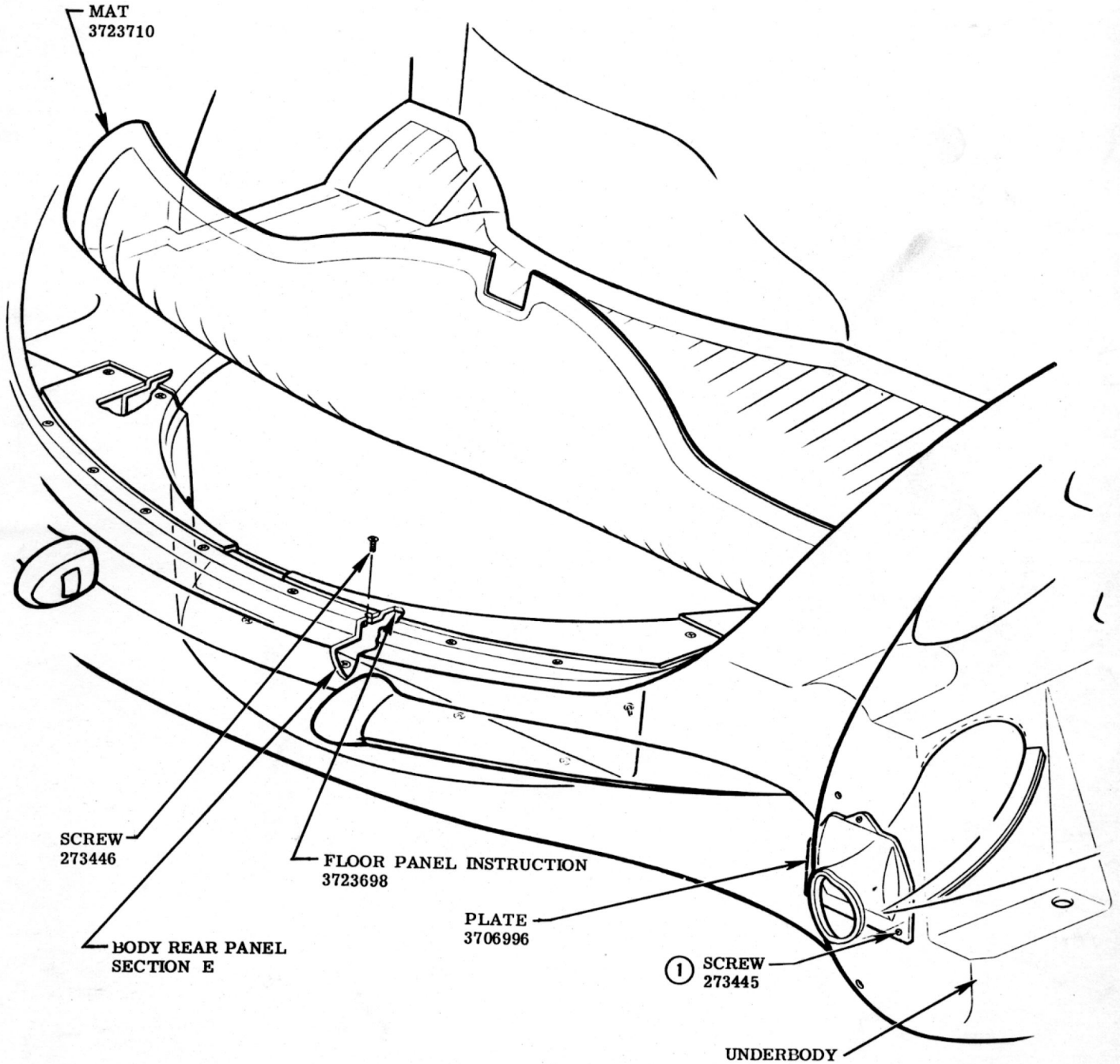

SHACKLE PLATE, REAR COMPARTMENT FLOOR PANEL & MAT

					NAME CORVETTE INSTRUCTION MANUAL				
					REF.	DRAWN O. W.	CHECKED L. S.	SECT.	SHEET
7-9-56	1	WAS 455625 RIVET	—	F	DATE 9-15-55	PART No. 3726900		A	4.00
DATE	SYM.	REVISION RECORD	AUTH.	DR.	CK.				