

TRANSMISSION LEVER & LINKAGE ADJUSTMENT

1. USING GAGE BLOCK, SET LEVERS (A), (E), (F) & (G) IN NEUTRAL POSITION. SET LEVERS (B), (C), & (D) IN NEUTRAL DETENT POSITION. INSTALL ROD (H) ON LEVER (E) AND INSERT CLIP.
2. ADJUST CLEVIS UNTIL CLEVIS PIN CAN BE FREELY ADMITTED THROUGH HOLES IN CLEVIS AND LEVER (B).
3. INSTALL CLEVIS PIN AND COTTER PIN.
4. MOVE LEVER (A) TO 1ST. & 2ND. SIDE MAINTAINING LEVER (A) IN NEUTRAL DETENT. INSTALL ROD (J) ON LEVER (F) AND INSERT CLIP.
5. ADJUST CLEVIS UNTIL CLEVIS PIN CAN BE FREELY ADMITTED THROUGH HOLES IN CLEVIS AND LEVER (C).
6. INSTALL CLEVIS PIN AND COTTER PIN.
7. MOVE LEVER (A) TO REVERSE SIDE MAINTAINING LEVER (A) IN NEUTRAL DETENT. INSTALL ROD (K) ON LEVER (G) AND INSERT CLIP.
8. ADJUST CLEVIS UNTIL CLEVIS PIN CAN BE FREELY ADMITTED THROUGH HOLES IN CLEVIS AND LEVER (D).
9. REMOVE GAGE BLOCK AND CHECK SHIFTS TO INSURE PROPER OPERATION. READJUST CLEVIS IF NECESSARY.

SEE LUBRICATION CHART

4 SPEED TRANSMISSION

					NAME CORVETTE INSTRUCTION MANUAL				
					REF.	DRAWN V	CHECKED F	R. P. O.	SHEET
4-9-57		RELEASED	139		DATE 11-26-56	PART No. 3726900		685	1.00
DATE	SYM.	REVISION RECORD	AUTH.	DR.	CK.				

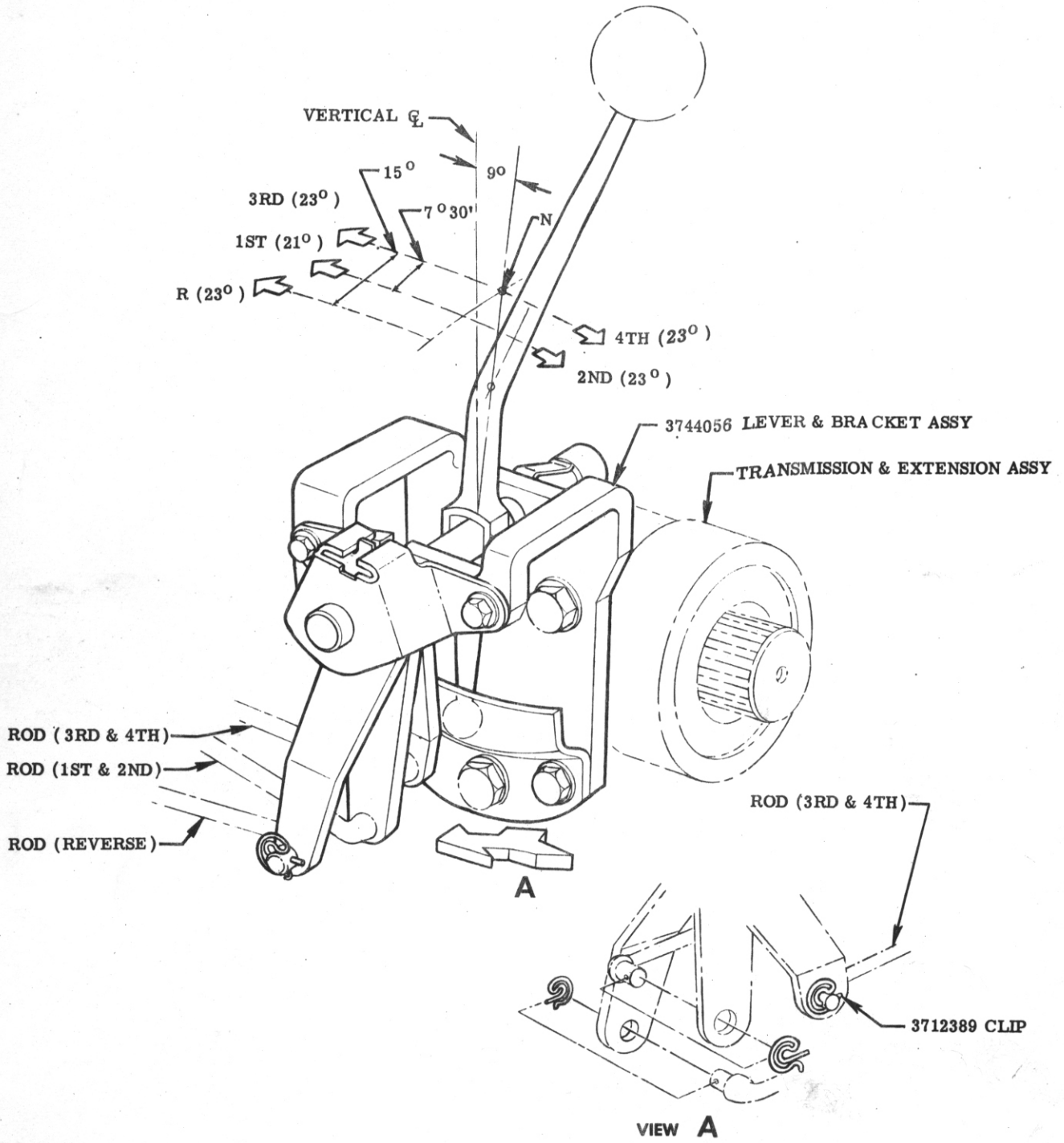

SEE LUBRICATION CHART

4 SPEED TRANSMISSION-CONTROL LEVER

					NAME					CORVETTE INSTRUCTION MANUAL				
					REF.		DRAWN		CHECKED		R. P. O.		SHEET	
							V		F		685		2.00	
4-9-57		RELEASED			139		DATE		PART No.		3726900			
DATE	SYM.	REVISION RECORD			AUTH.	DR.	CK.	11-26-56						