

WYLLIAMS PUBLISHING COMPANY  
11100 GARDEN CITY ROAD  
GARDEN CITY, N.Y. 11530

WYLLIAMS PUBLISHING COMPANY



MINOR BRAKE ADJUSTMENT

1. TURN BRAKE ADJUSTING SCREW (VIEW A) TO EXPAND BRAKE SHOES UNTIL A LIGHT UNIFORM DRAG IS FELT WHEN ROTATING DRUM WITH BOTH HANDS AT TIRE RADIUS.
2. TURN BRAKE ADJUSTING SCREW BACK TO CONTACT BRAKE SHOES, FOURTEEN NOTCHES OF STAR WHEEL SO AS TO INSURE RUNNING CLEARANCE AND GOOD FEEL AT BRAKE PEDAL.

MAJOR BRAKE ADJUSTMENT

1. LOOSEN ANCHOR PIN NUT ENOUGH TO ALLOW ANCHOR PIN TO SHIFT IN SLOT IN FLANGE PLATE WITHOUT TILTING.
2. TURN BRAKE ADJUSTING SCREW (STAR WHEEL) TO EXPAND BRAKE SHOES UNTIL A UNIFORM MODERATE DRAG IS FELT WHEN ROTATING DRUM. AT THE SAME TIME AS ADJUSTING SCREW IS BEING MOVED TO EXPAND SHOES, FLANGE PLATE SHOULD BE TAPPED LIGHTLY WITH HAMMER TO HELP ANCHOR PIN TO FIND THE CORRECT CENTER.
3. TIGHTEN ANCHOR PIN NUT ENOUGH TO KEEP PIN SNUG BUT NOT SO TIGHT THAT IT CAN NOT BE MOVED UP OR DOWN IN SLOT WITH LIGHT TAP OF HAMMER.
4. BACK OFF BRAKE ADJUSTING SCREW APPROX. TEN NOTCHES AND IF NECESSARY, TAP LIGHTLY UPWARD OR DOWNWARD ON ANCHOR PIN UNTIL .010 FEELER CAN BE INSERTED AT BOTH HEEL & TOE OF SECONDARY FACING WITH EQUAL DRAG.
5. TIGHTEN ANCHOR PIN NUT TO TORQUE OF 60 TO 80 LBS. FT.
6. RECHECK .010 CLEARANCE AT TOE & HEEL OF SECONDARY SHOE IT MAY BE NECESSARY TO GO OVER STEPS 4 & 5 IF THE ANCHOR PIN NUT TIGHTENING CAUSES A SHIFTING OF THE CLEARANCE.
7. REPLACE TIRE & WHEEL.
8. TURN BRAKE ADJUSTING SCREW TO EXPAND BRAKE SHOES UNTIL A LIGHT UNIFORM DRAG IS FELT WHEN ROTATING DRUM WITH BOTH HANDS AT THE RADIUS.
9. TURN BRAKE ADJUSTING SCREW BACK TO CONTACT BRAKE SHOES FOURTEEN NOTCHES OF STAR WHEEL SO AS TO INSURE RUNNING CLEARANCE AND GOOD FEEL OF BRAKE PEDAL.

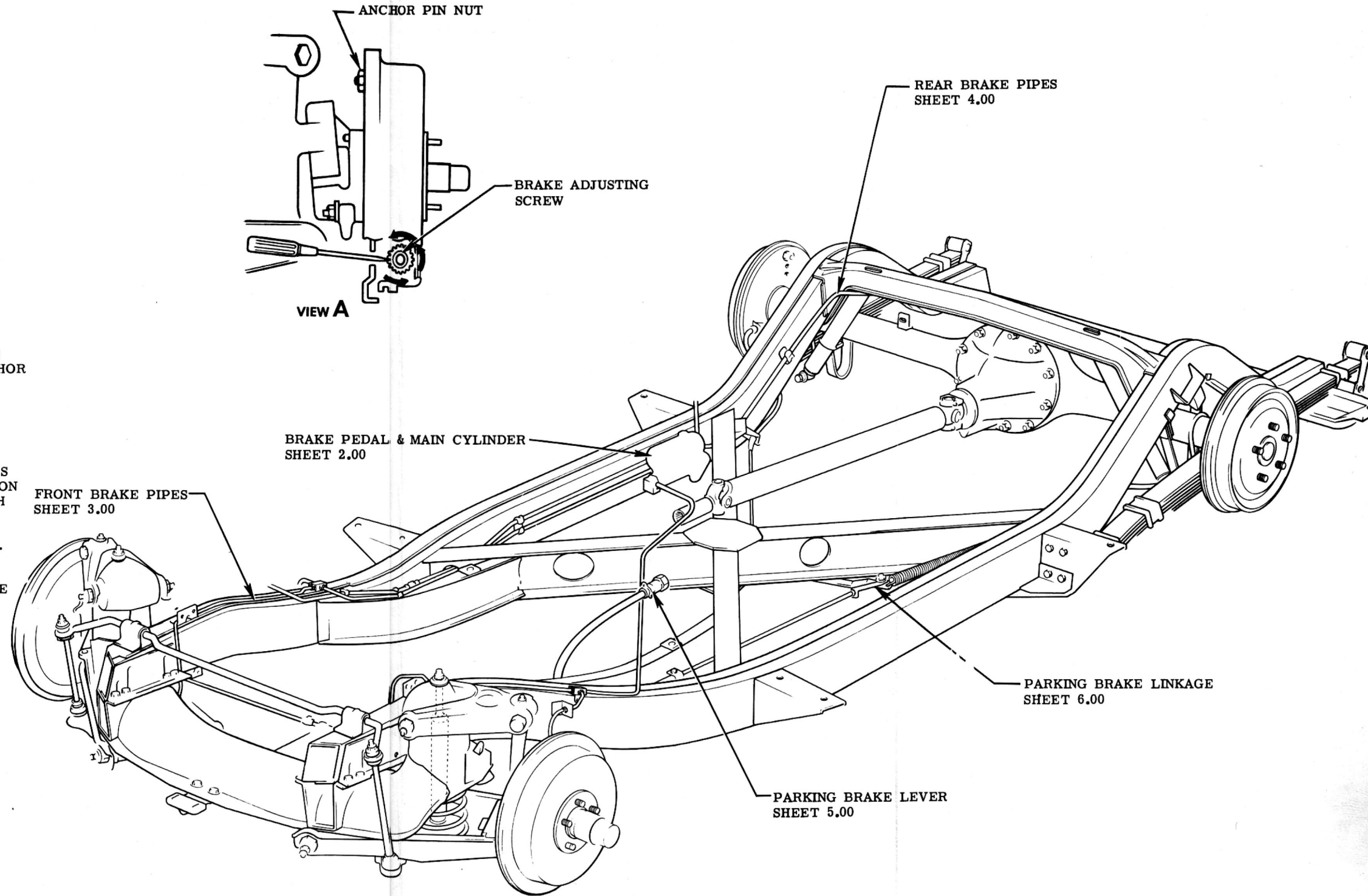

SEE LUBRICATION CHART SECTION 14

**BRAKES**

						NAME CORVETTE INSTRUCTION MANUAL				
						REF.	DRAWN O.W.	CHECKED N.D.	SECT.	SHEET
						DATE	PART No.		5	1.00
						9-15-55	3726900			
DATE	SYM.	REVISION RECORD	AUTH.	DR.	CK.					

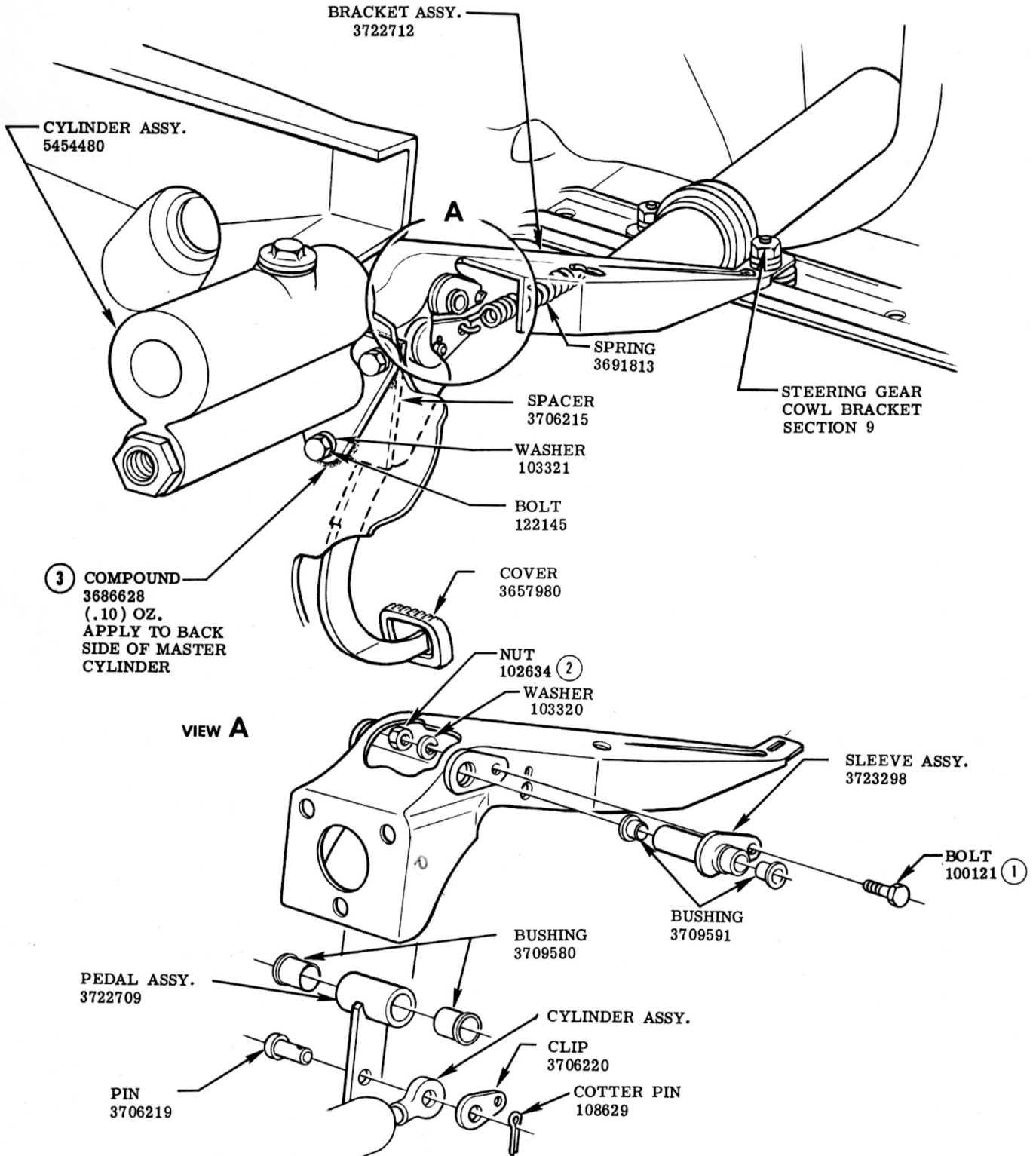

SEE LUBRICATION CHART SECTION 14  
**BRAKE PEDAL & MAIN CYLINDER**

						CORVETTE INSTRUCTION MANUAL				
DATE	SYM.	REVISION RECORD	AUTH.	DR.	CK.	REF.	DRAWN O. W.	CHECKED N. D.	SECT.	SHEET
11-13-56	3	PART ADDED	4059	V	F				5	2.00
	2	WAS 103025			F					
10-11-56	1	WAS 100013	3729							
						DATE 9-15-55	PART No. 3726900			

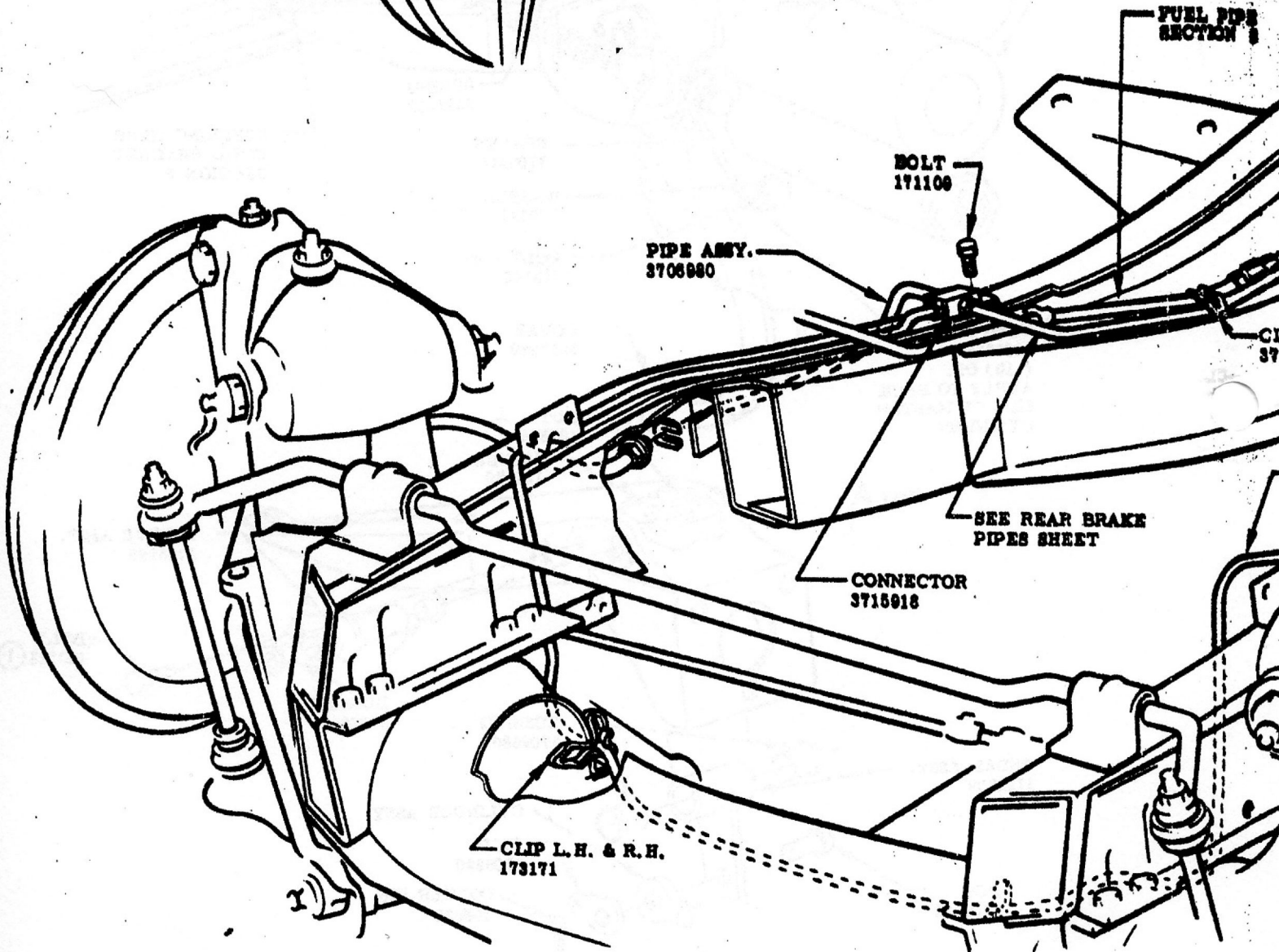
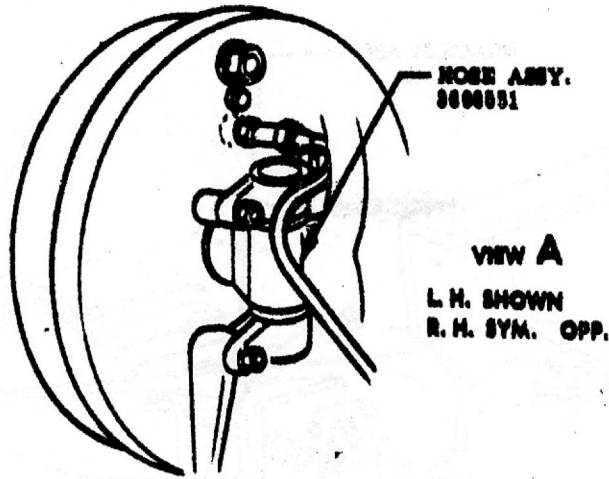
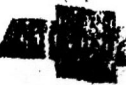

SEE LUBRICATION CHART SECTION 14

FRONT BRAKE PIPES

GENERAL MOTORS CORPORATION

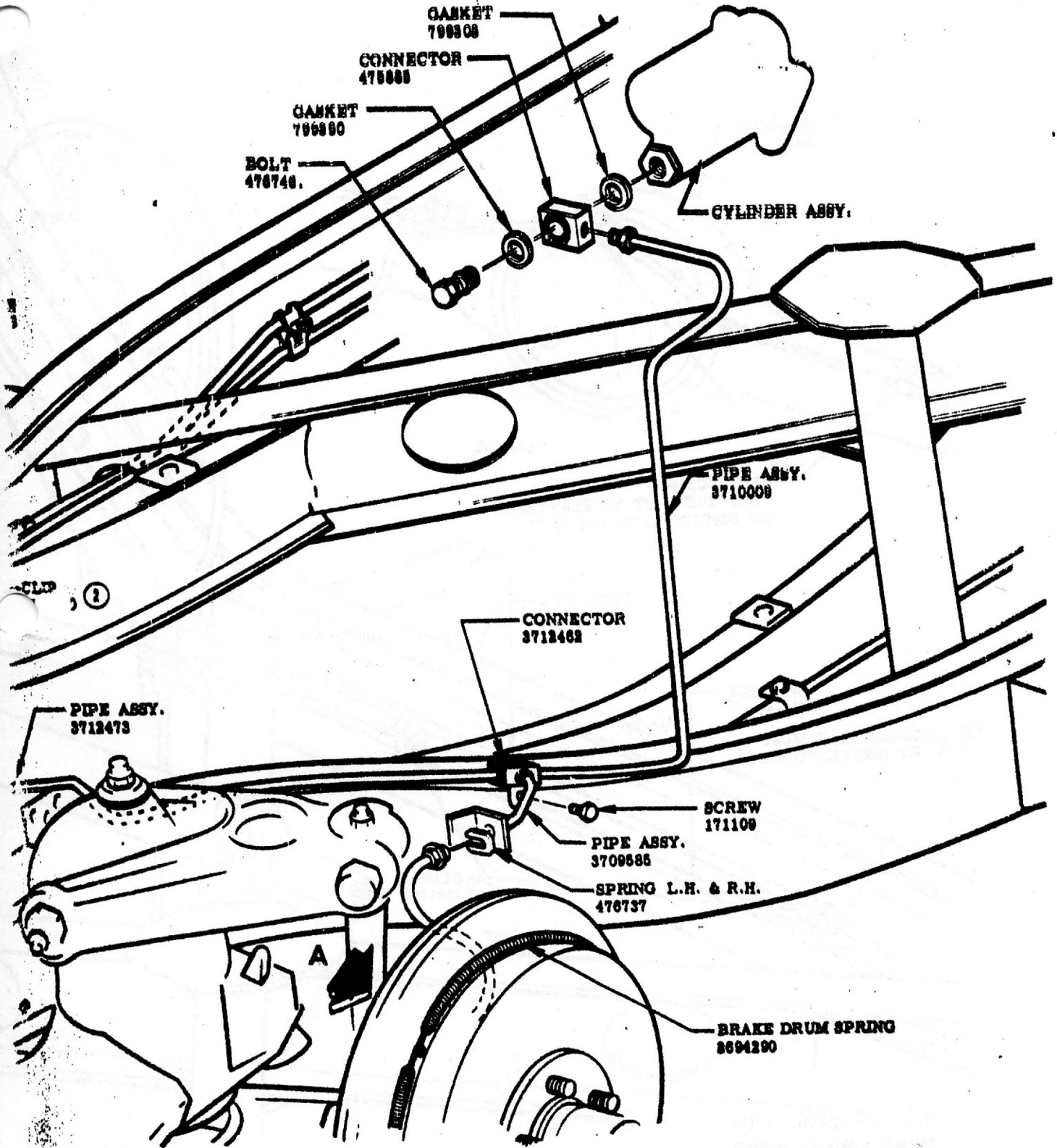

					NAME CORVETTE INSTRUCTION MANUAL				
					REF.	DRAWN	CHECKED	SECT.	SHEET
						O. W.	N. D.	5	3.00
9-5-56	2	WAS 3696562	3818	F	DATE	PART No.	3726900		
7-31-56	1	REDRAWN & REVISED FOR 57	7616	F	9-15-55				
DATE	SYM.	REVISION RECORD	AUTH.	DR.	CK.				

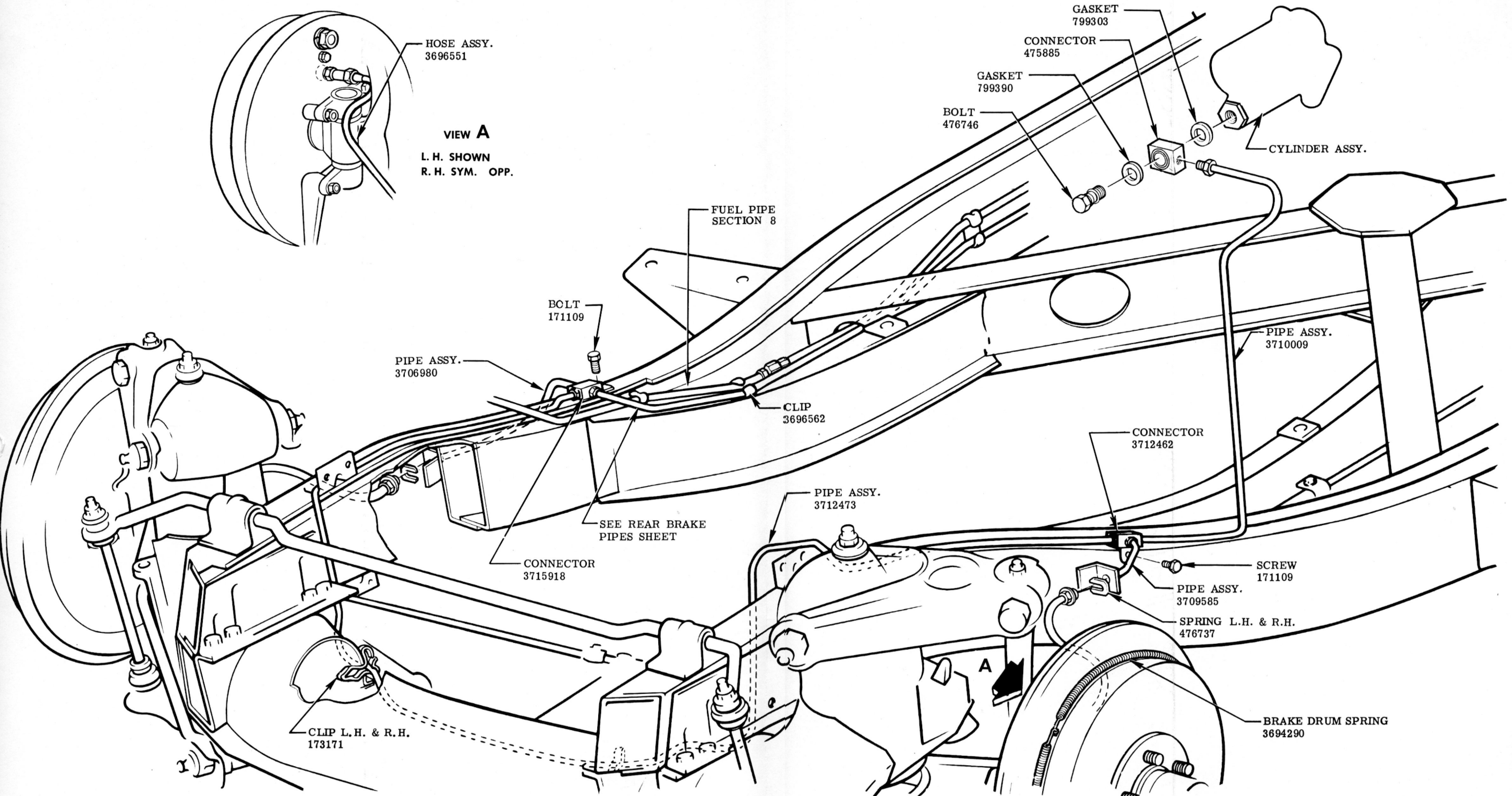

SEE LUBRICATION CHART SECTION 14

**FRONT BRAKE PIPES**

							CORVETTE INSTRUCTION MANUAL				
							REF.	DRAWN	CHECKED	SECT.	SHEET
								O. W.	N. D.		
7-31-56	1	REDRAWN & REVISED FOR 57	7616	F	DATE	9-15-55	PART No.	3726900	5	3.00	
DATE	SYM.	REVISION RECORD	AUTH.	DR.	CK.						

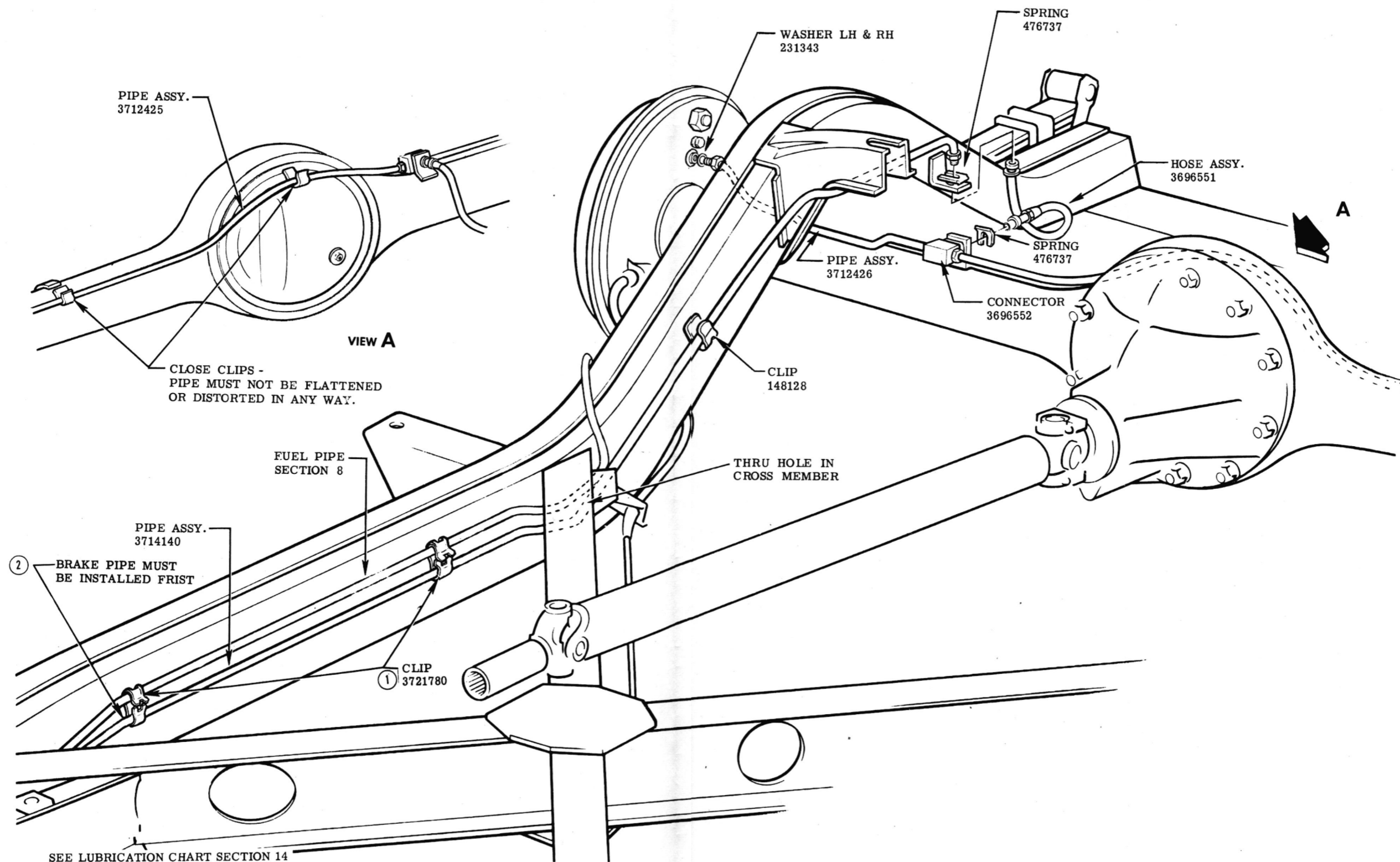

**REAR BRAKE PIPES**

							NAME				CORVETTE INSTRUCTION MANUAL			
							REF.	DRAWN	O.W.	CHECKED	L.S.	SECT.	SHEET	
							2	NOTE ADDED			F			
9-5-56	1	WAS 3696562			3818	DATE			PART No. 3726900					
DATE	SYM.	REVISION RECORD			AUTH.	DR.	CK.	9-15-55	5 4.00					

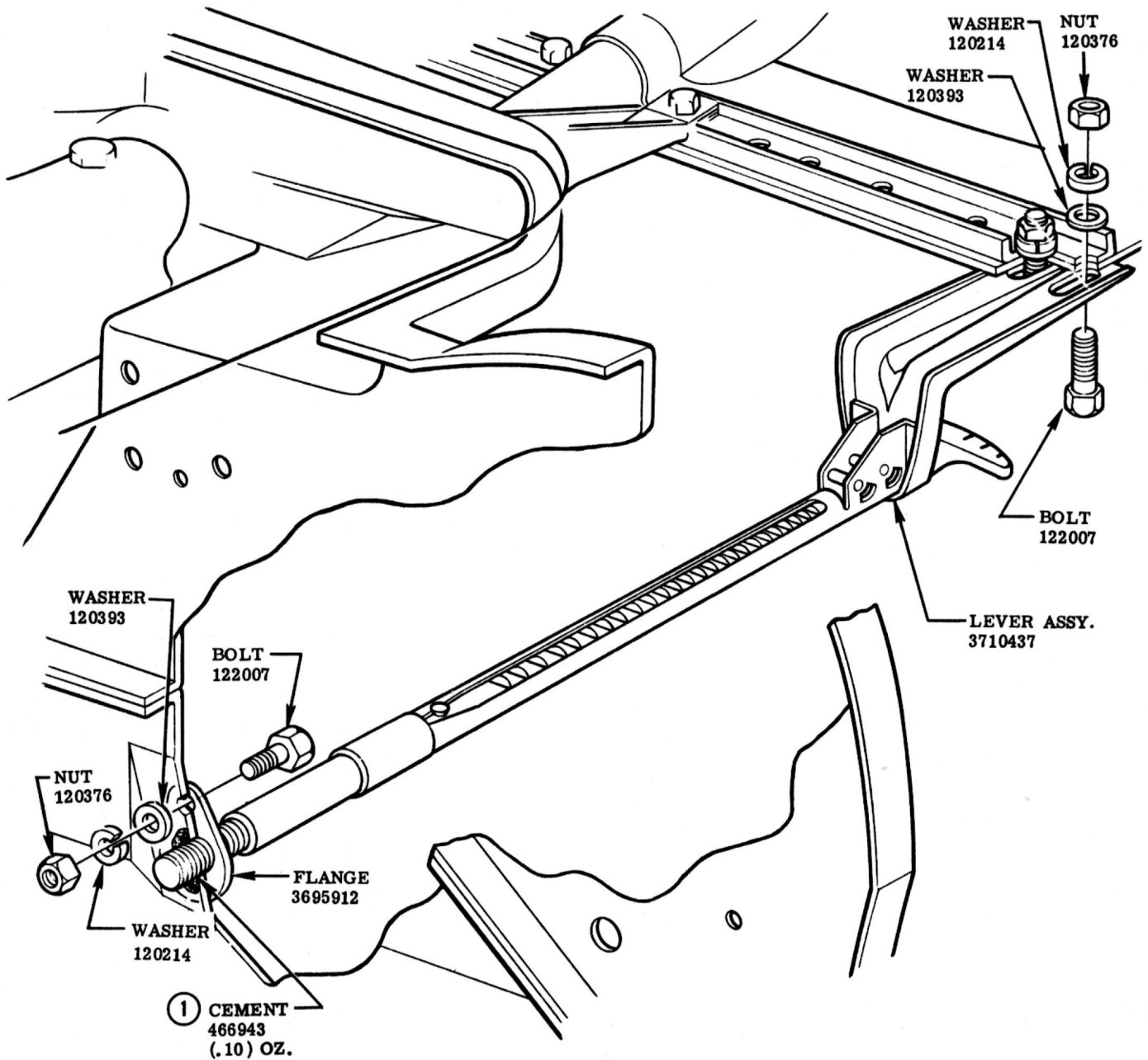

PARKING BRAKE ADJUSTMENT

TENSION ON BOTH CABLES MUST BE SUCH THAT WHEN CAR IS BROUGHT TO A FAST STOP FROM 15 M.P.H. BY APPLYING THE HAND BRAKE, ONE WHEEL WILL NOT SLIDE OR LOCK BEFORE THE OTHER BY MORE THAN 5 FEET WHEN CHECKED ON DRY CONCRETE PAVEMENT.

TO GUARD AGAINST TOO TIGHT OR TOO LOOSE ADJUSTMENT OF THE CABLES, THE PULL ON THE HAND BRAKE LEVER MUST BE 25-35 Lbs. AT 7 CLICKS OF THE RATCHETS. (THIS LOAD MUST BE NOTICEABLY AFFECTED BY ANY FRICTION IN THE HAND BRAKE SYSTEM.)

PARKING BRAKE LEVER SEE LUBRICATION CHART SECTION 14

					NAME CORVETTE INSTRUCTION MANUAL				
					REF.	DRAWN O.W.	CHECKED L.S.	SECT.	SHEET
11-13-56	1	PART ADDED	4059	V F	DATE 9-15-55	PART No. 3726900	5	5.00	
DATE	SYM.	REVISION RECORD	AUTH.	DR. CK.					



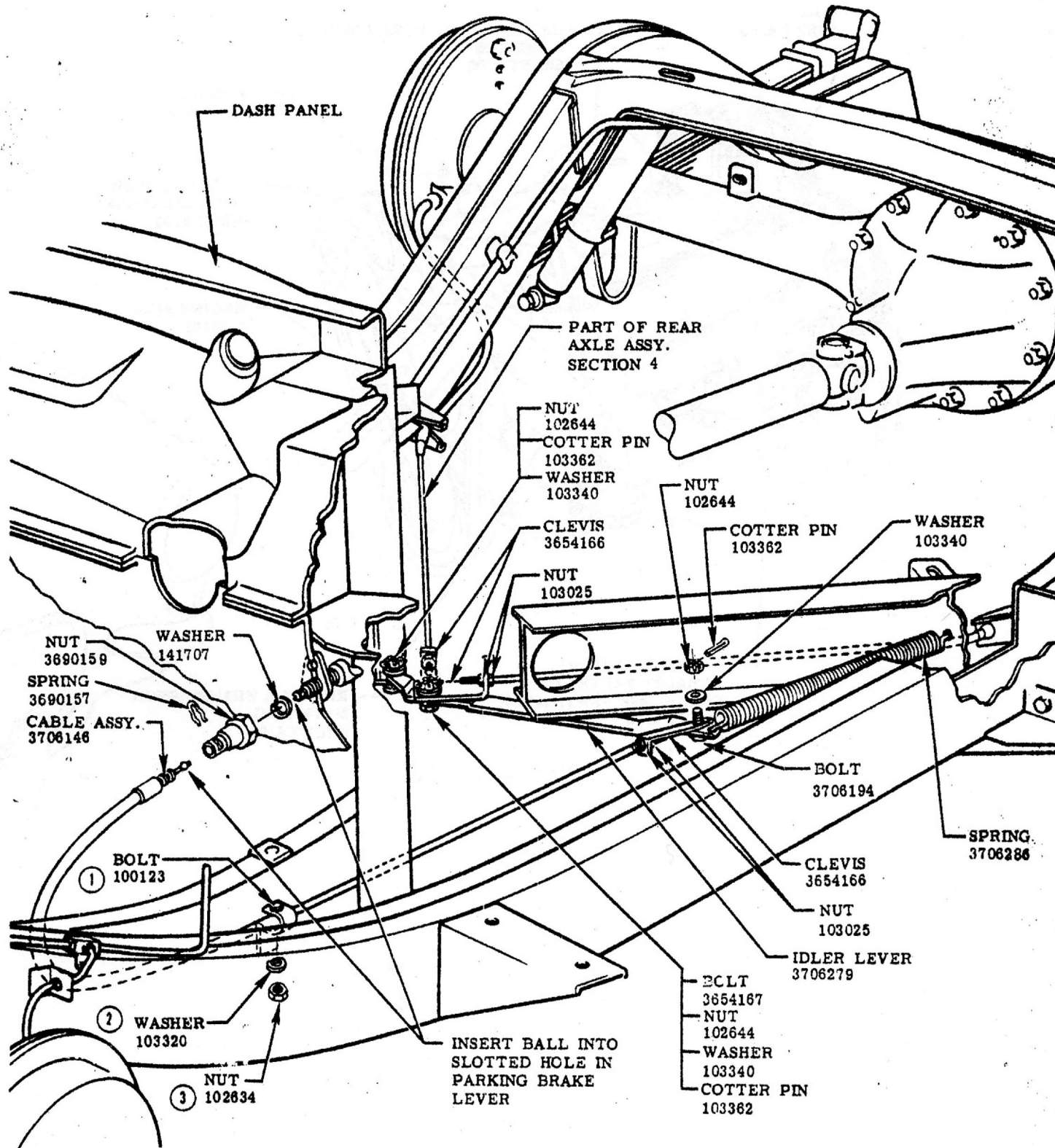

**PARKING BRAKE LINKAGE**

					NAME				CORVETTE INSTRUCTION MANUAL			
					REF.	DRAWN	CHECKED	SECT.	SHEET			
						O. W.	L. S.					
2-22-56	3	WAS 120376			DATE	PART No.		5			6.00	
	2	WAS 120214			9-15-55	3726900						
	1	WAS 122027	5344									
DATE	SYM.	REVISION RECORD	AUTH.	DR.	CK.							

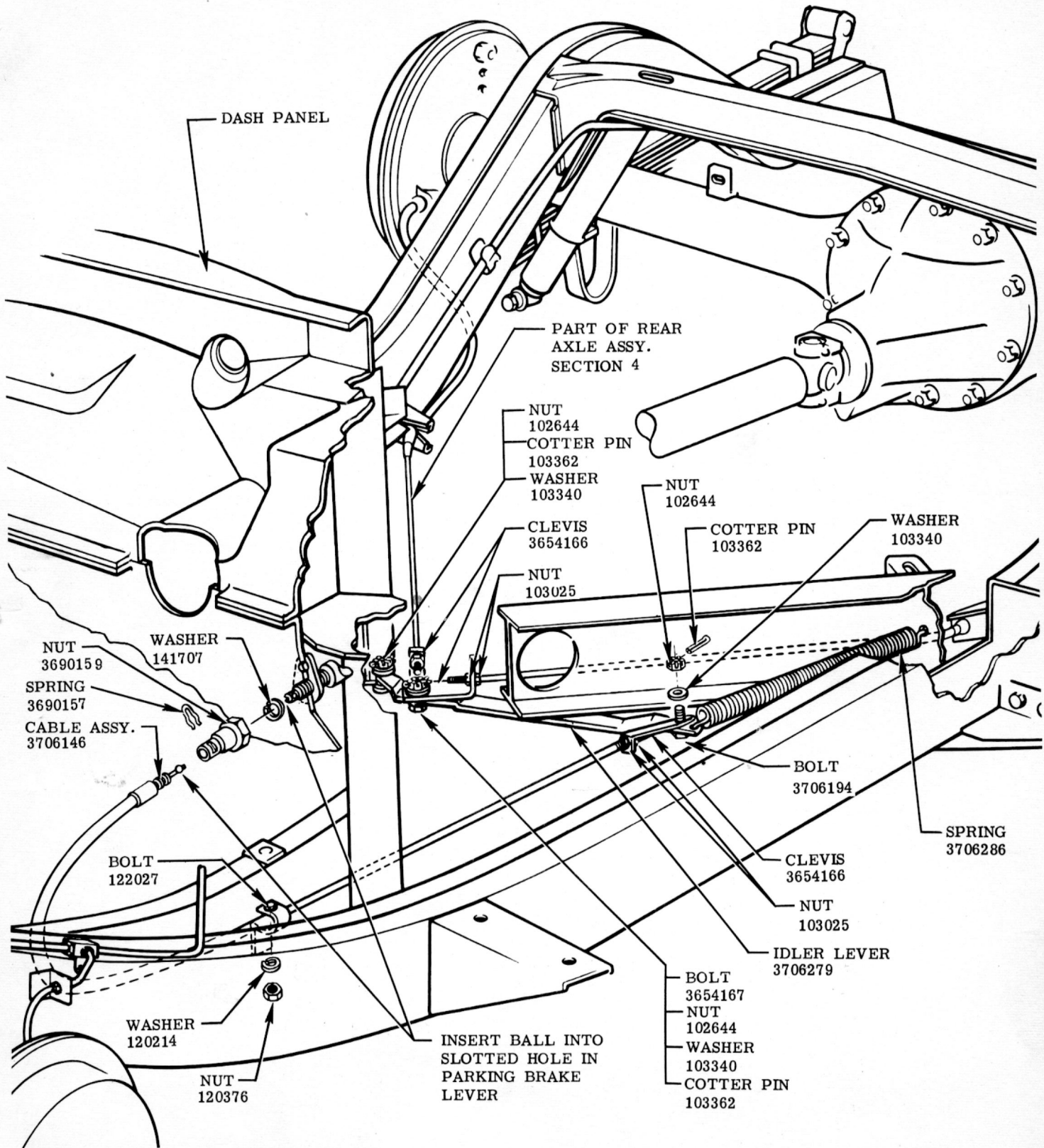

**PARKING BRAKE LINKAGE**

						NAME	CORVETTE INSTRUCTION MANUAL			
						REF.	DRAWN O. W.	CHECKED L. S.	SECT.	SHEET
						DATE	PART No.		5	6.00
DATE	SYM.	REVISION RECORD	AUTH.	DR.	CK.	9-15-55	3726900			