

AIR CLEANERS, CARBURETORS AND FUEL PIPES

DATE	SYM.	REVISION RECORD	AUTH.	DR.	CK.	NAME	CORVETTE INSTRUCTION MANUAL			R. P. O.	SHEET
3-15-57	13	VIEW "A" ADDED	325		F	REF. 8858	DRAWN	V	CHECKED	F	
	12	PART ADDED	7519	V		8242					
	11	WAS 3720953			F						
	10	WAS 3730599									
12-11-56	9	REDRAWN	5805			DATE	PART No.			469	1.00
						5-28-56	3726900				

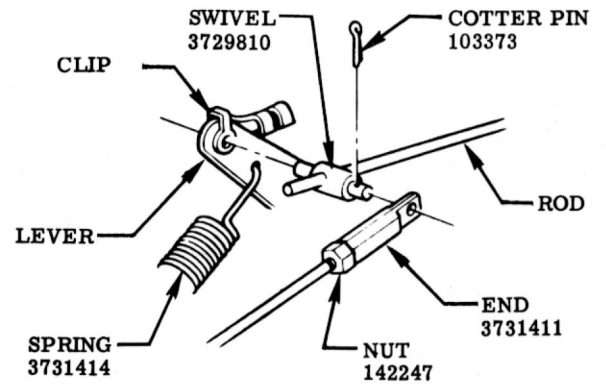
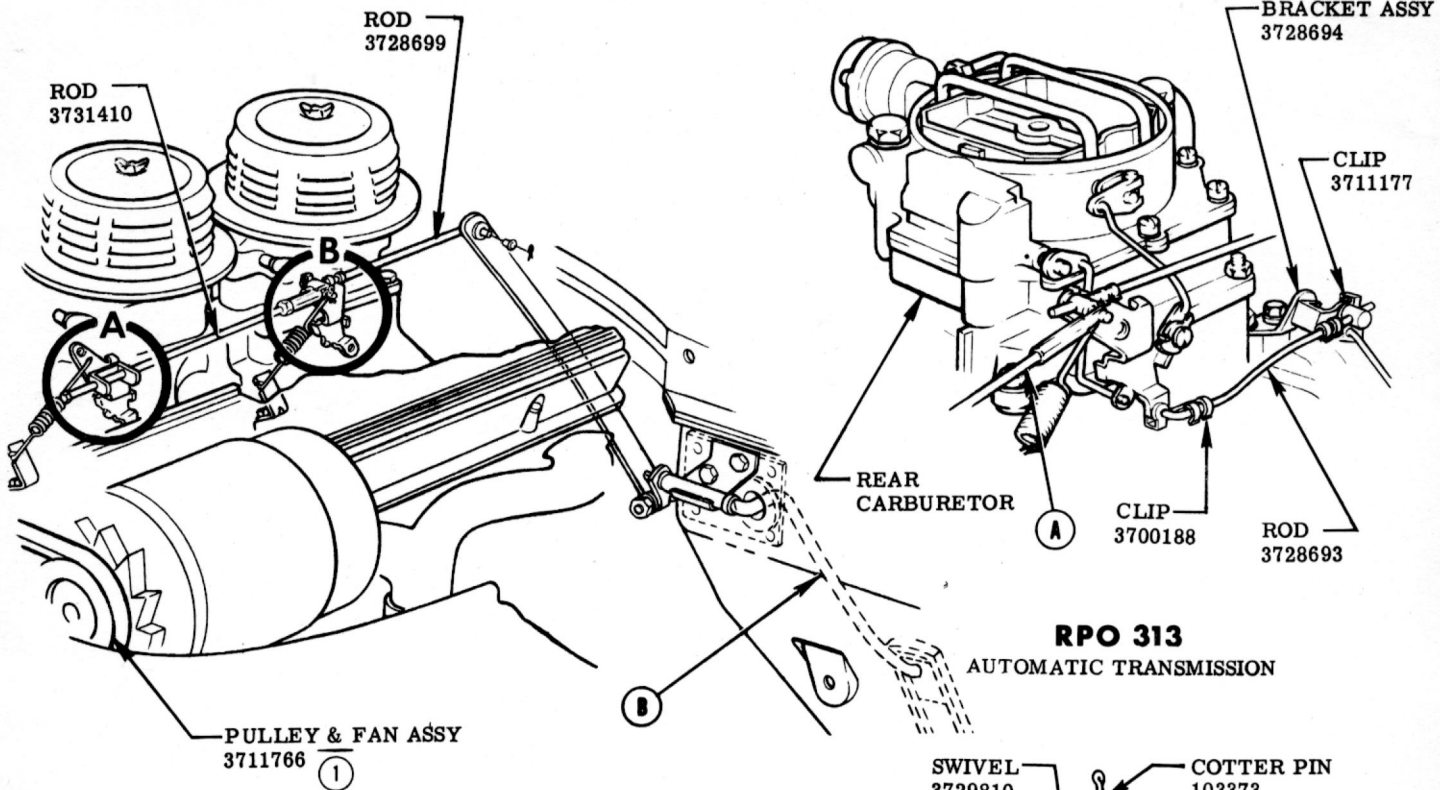

VIEW B

3 SPEED TRANSMISSION

WITH ACCELERATOR PEDAL ROD (B) .38 FROM UNDERBODY (CARPET REMOVED) SET ACCELERATOR CONTROL ROD TO GIVE WIDE OPEN THROTTLE ON REAR CARBURETOR. WITH REAR CARBURETOR IN WIDE OPEN POSITION, ADJUST CARBURETOR THROTTLE LEVER CONTROL ROD TO GIVE WIDE OPEN THROTTLE ON FRONT CARBURETOR.

RPO 313
AUTOMATIC TRANSMISSION

MAKE ADJUSTMENTS ON REAR CARBURETOR SAME AS RPO 313. THEN ADJUST ROD (A) TO GIVE WIDE OPEN THROTTLE ON FRONT CARBURETOR.

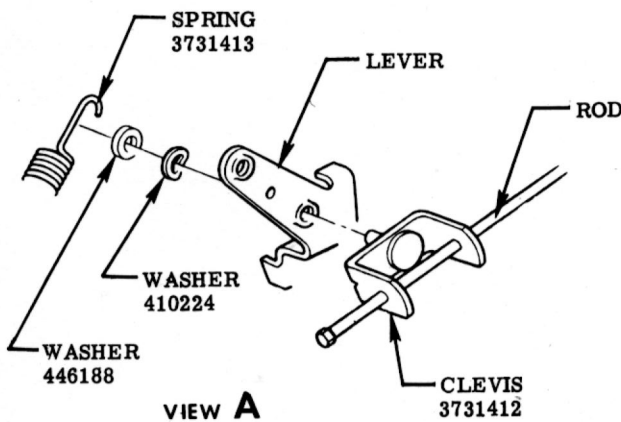

VIEW A

ACCELERATOR & GEN. PULLEY (2)

					CORVETTE INSTRUCTION MANUAL					
DATE	SYM.	REVISION RECORD	AUTH.	DR.	CK.	REF.	DRAWN	CHECKED	R. P. O.	SHEET
	2	TITLE REVISED				8242	V	F		
7-23-56	1	PART ADDED	1123	V		DATE	PART No.		469	2.00
						5-28-56	3726900			