

313 TRANS-
MISSION

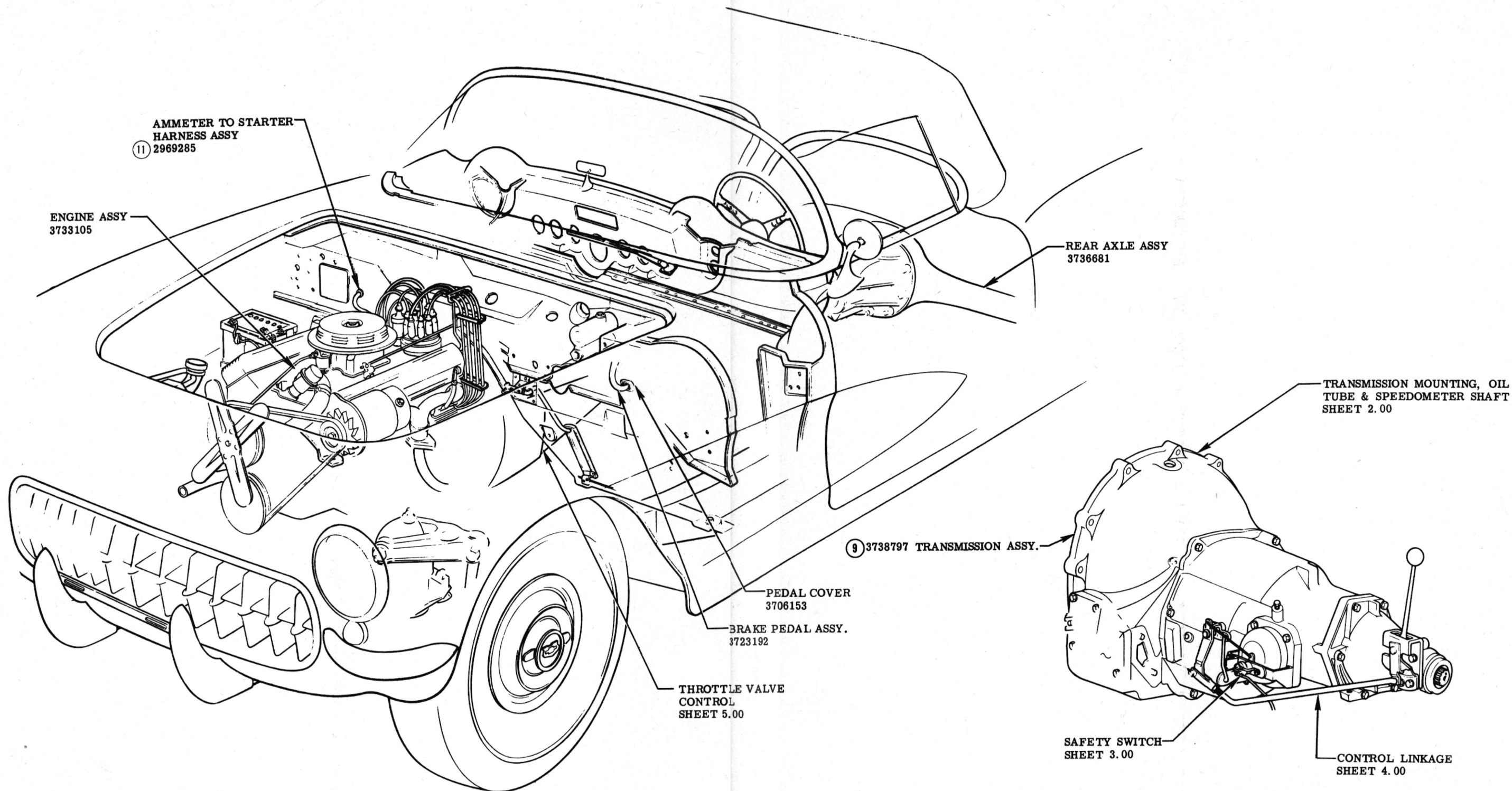

10

SEE LUBRICATION CHART SECTION 14
AUTOMATIC TRANSMISSION

CORVETTE INSTRUCTION MANUAL					
11	WAS 2968412	325		F	
10	NOTE REMOVED				
9	WAS 3743597				
2-27-57	8	REDRAWN	7981		
DATE	SYM.	REVISION RECORD	AUTH.	DR.	CK.
			NAME		CORVETTE INSTRUCTION MANUAL
			REF.	DRAWN	CHECKED
				J.J.	L.S.
			DATE	PART No.	R. P. O.
			9-15-55	3726900	313
					SHEET
					1.00

Chwary

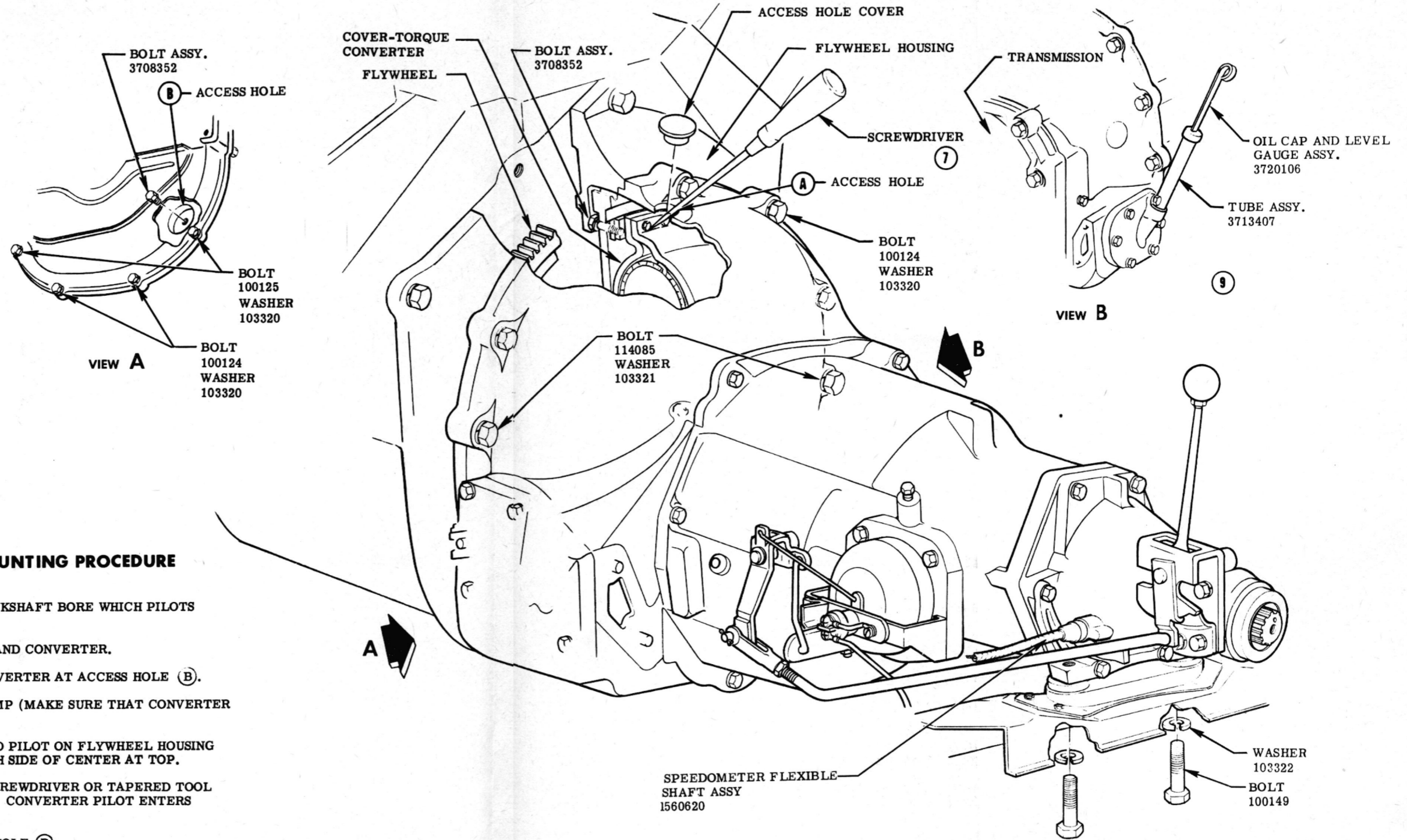

ⓘ SUGGESTED ENGINE MOUNTING PROCEDURE

1. PUT FILM OF LUBRIPLATE IN CRANKSHAFT BORE WHICH PILOTS CONVERTER COVER.
2. ALIGN BOLT HOLES IN FLYWHEEL AND CONVERTER.
3. INSTALL GUIDE PIN IN NUT ON CONVERTER AT ACCESS HOLE (B).
4. REMOVE CONVERTER SAFETY CLAMP (MAKE SURE THAT CONVERTER HAS NOT SLIPPED FORWARD)
5. ENTER TRANSMISSION HOUSING INTO PILOT ON FLYWHEEL HOUSING AND ASSEMBLE ONE HOLE ON EACH SIDE OF CENTER AT TOP.
6. PRY CONVERTER UPWARD USING SCREWDRIVER OR TAPERED TOOL THROUGH ACCESS HOLE (A) UNTIL CONVERTER PILOT ENTERS HOLE IN CRANKSHAFT.
7. REMOVE PILOT PIN FROM ACCESS HOLE (B).
8. DRIVE FLYWHEEL TO CONVERTER BOLTS.
9. DRIVE FLYWHEEL HOUSING BOLTS.
10. DRIVE OIL FILLER PLUG INTO ACCESS HOLE (A)
11. REASSEMBLE FLYWHEEL HOUSING COVER.

SEE LUBRICATION CHART SECTION 14

TRANSMISSION MOUNTING SPEEDOMETER SHAFT & OIL TUBE

CORVETTE INSTRUCTION MANUAL					
REF.	DATE	SYM.	AUTH.	DR.	CK.
		9	NOTE REMOVED		F
		8	PROCEDURE REVISED		
5-27-57		7	NOTE ADDED	8829	V
7-31-56		6	REDRAWN & REVISED FOR 57	6937	V F
DATE	SYM.		REVISION RECORD	AUTH.	DR. CK.

NAME	CORVETTE INSTRUCTION MANUAL			
REF.	DRAWN J. J.	CHECKED L. S.	R. P. O.	SHEET
DATE 9-15-55	PART No. 3726900		313	2.00

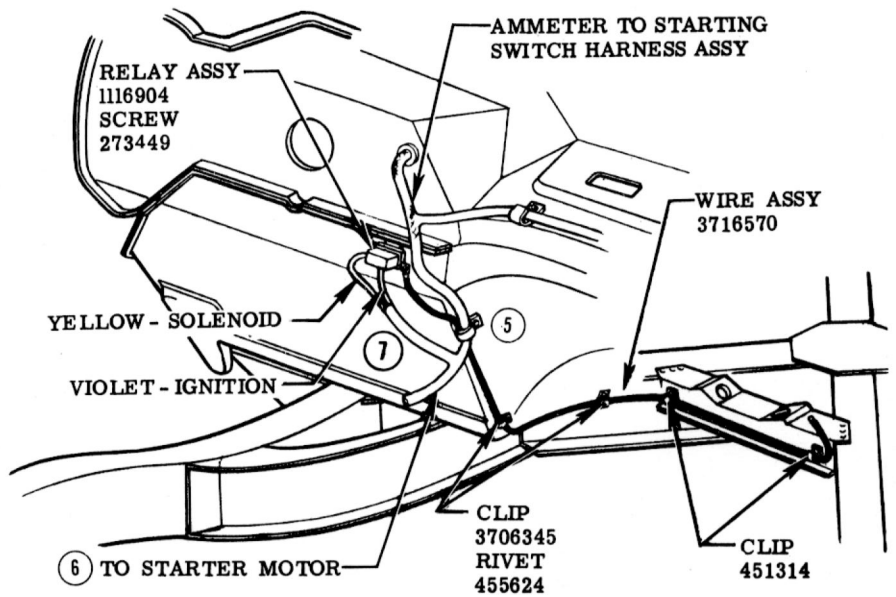
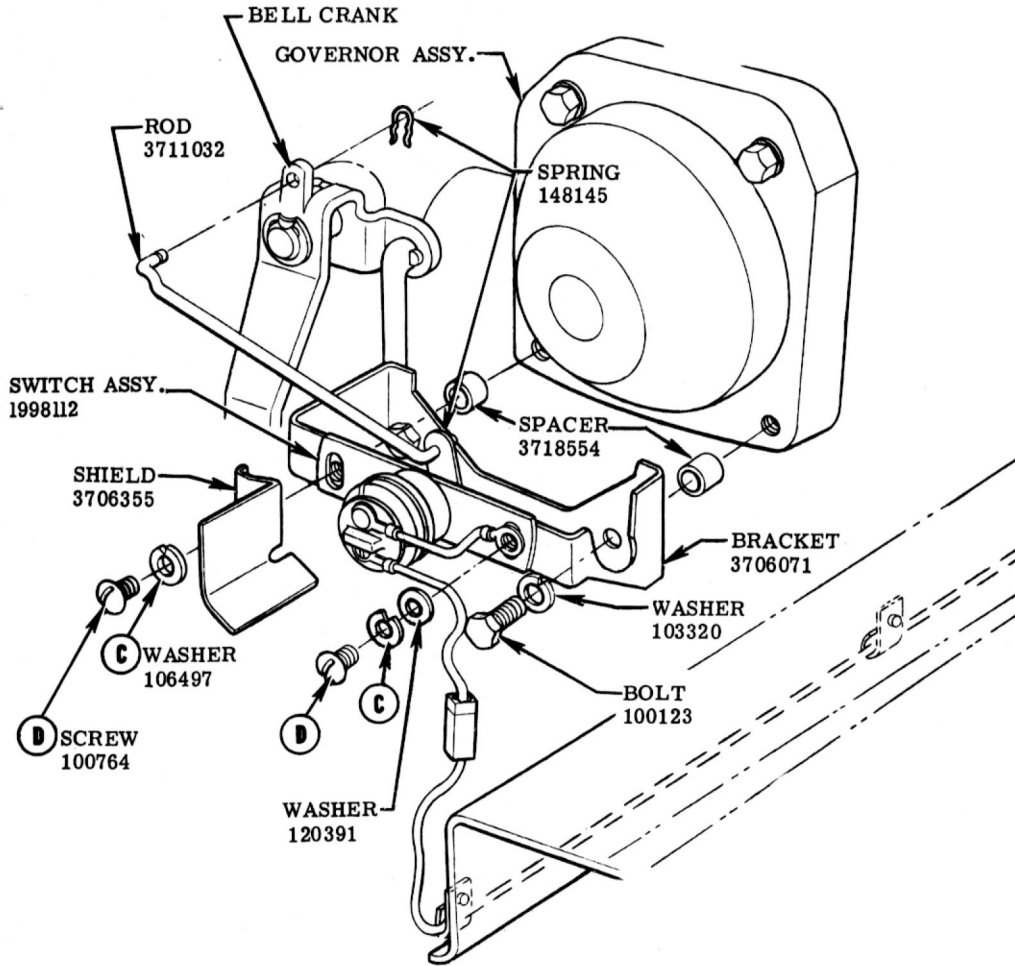

TRANSMISSION SAFETY SWITCH & STARTER RELAY

3-15-57	7	HARNESS REROUTED		V	F	NAME	CORVETTE INSTRUCTION MANUAL			
	6	NOTE ADDED			F					
1-21-57	5	CLIP NO. 3706345 AND RIVET NO. 455624 REMOVED	231			DATE	PART No.		313	3.00
7-31-56	4	REDRAWN & REVISED FOR 57	9463	V	F	9-15-55	3726900			
DATE	SYM.	REVISION RECORD		AUTH.	DR.	CK.				

TRANSMISSION GEARSHIFT CONTROL
ADJUSTMENT

1. SET CONTROL ROD BELL CRANK (U) IN PARKED POSITION.
2. SET CONTROL SHAFT LEVER (S) IN PARKED POSITION.
3. WITH BOTH BELL CRANK AND LEVER HELD IN PARK POSITION, ASSEMBLE CONTROL ROD (V) TO LEVER (S), THEN ADJUST CLEVIS ON ROD (V) FOR EASY ENTRY INTO LEVER (U).

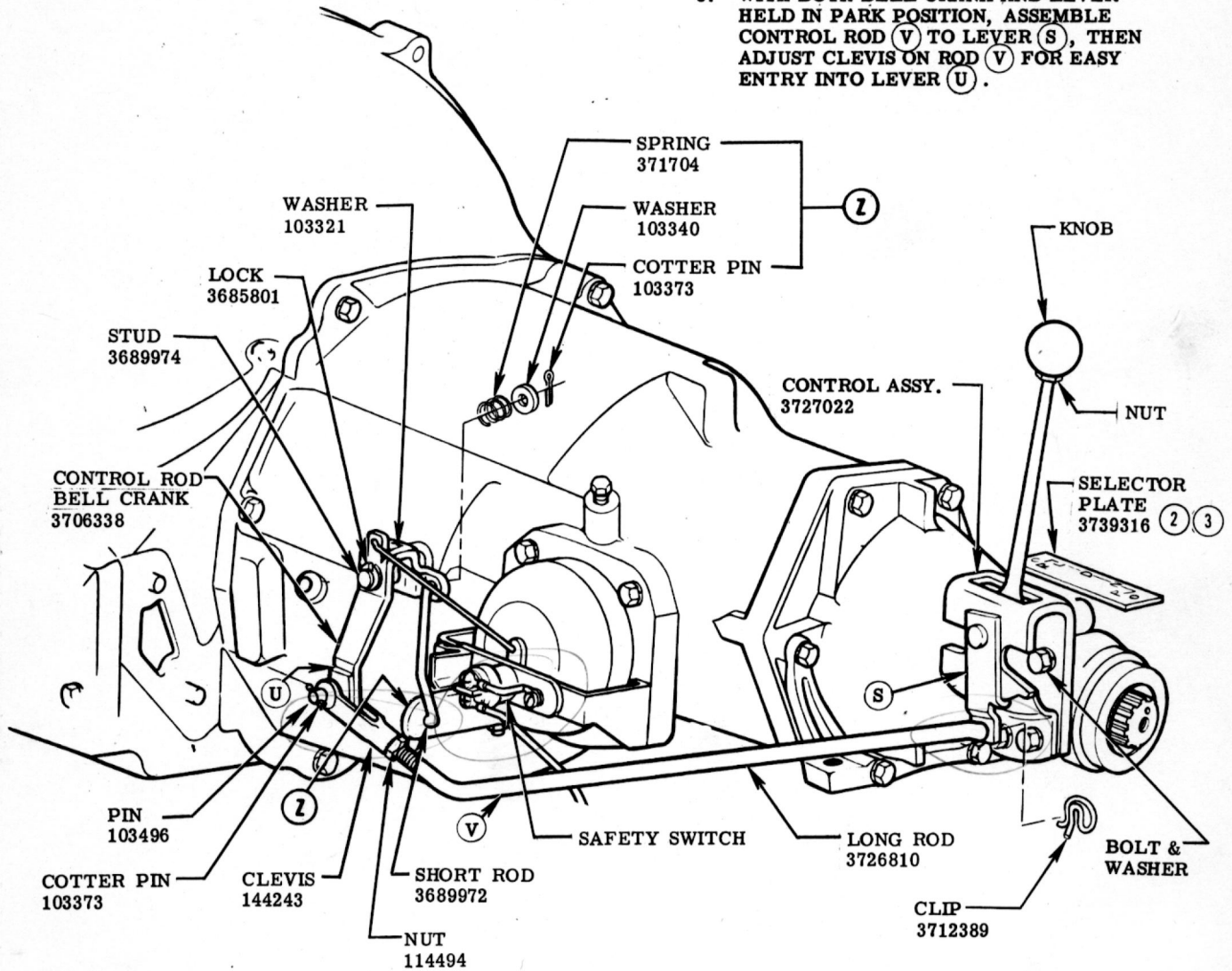

SEE LUBRICATION CHART SECTION 14

CONTROL LEVER & LINKAGE

					NAME CORVETTE INSTRUCTION MANUAL					
DATE	SYM.	REVISION RECORD	AUTH.	DR.	CK.	REF.	DRAWN J. J.	CHECKED L. S.	R. P. O.	SHEET
10-11-56	3	WAS 3734020		3742	F				313	4.00
2-22-56	2	WAS 3728937		6772	F					
2-2-56	1	REDRAWN & REVISED		6022	V F					
						DATE 9-15-55	PART No. 3726900			

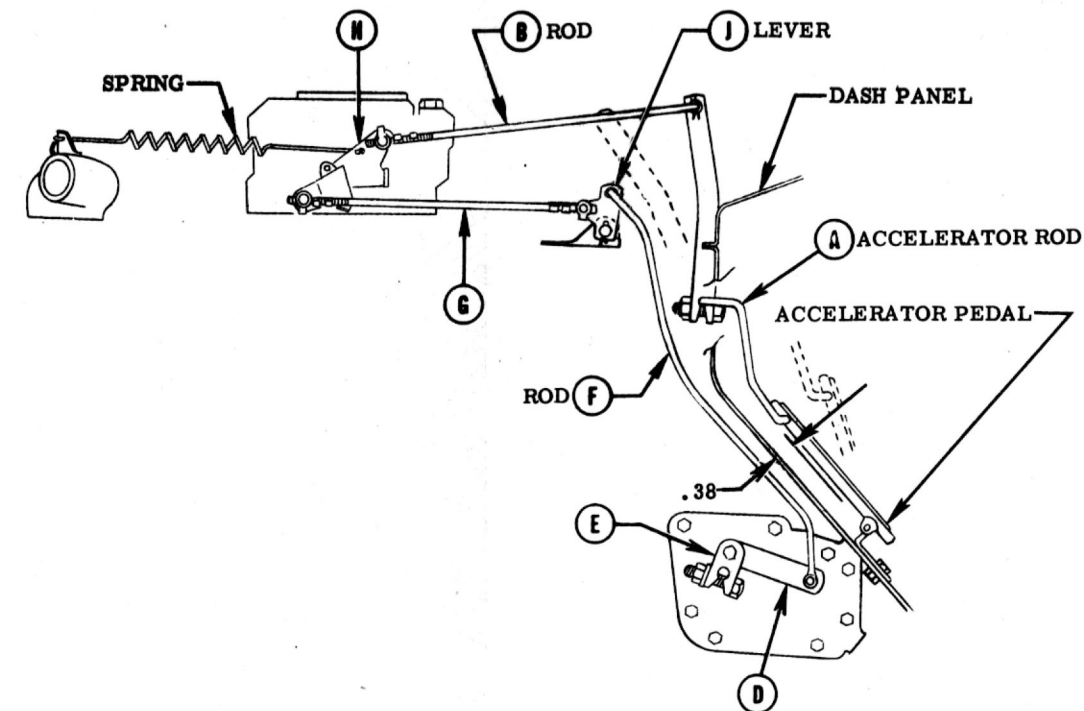
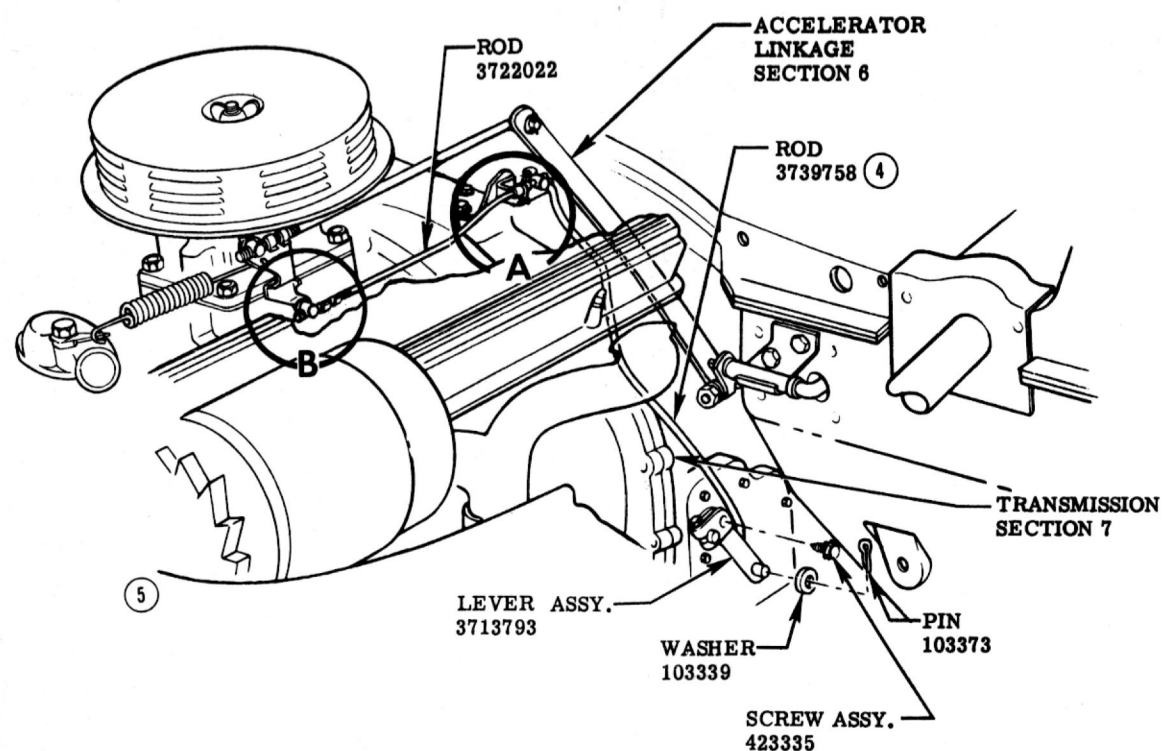

AUTOMATIC TRANSMISSION ADJUSTMENT

- 1 LOOSELY ASSEMBLE LEVER (D) TO CLAMP (E) .
- 2 INSERT GAUGE BETWEEN TRANSMISSION LEFT HAND SIDE COVER LOWER REAR BOLT & LOWER HOLE IN LEVER (D) 2.88 DIMENSION BETWEEN BOLT & HOLE CENTERLINES WITH GAUGE IN PLACE, AND HOLDING CLAMP (E) COUNTER CLOCKWISE IN FULL DETENT POSITION, TIGHTEN LEVER (D) TO CLAMP (E) REMOVE GAUGE.
- 3 INSTALL ROD (F).
- 4 INSTALL ROD (G) IN LEVER (J) . PLACE LEVER (H) IN WIDE OPEN POSITION & PULL ROD (F) UPWARD UNTIL IT IS STOPPED BY TRANSMISSION INTERNAL STOP. ADJUST SWIVEL IN ROD (G) FOR EASY ENTRANCE IN LEVER (H) BEFORE FIXING SWIVEL IN LEVER (H) .
- 5 CHECK ADJUSTMENT BY PLACING LINKAGE IN IDLE POSITION, THEN RETURNING TO WIDE OPEN POSITION BY ROTATING LEVER (H) PUSH UPWARD ON LEVER (D) AND NOTE IF ROD DEFLECTS, MEANING TRANSMISSION IS NOT ON INTERNAL STOP. IF ROD DEFLECTS OR LEVER (D) WILL NOT REACH WIDE OPEN POSITION, REPEAT ADJUSTMENT 4.
- 6 WITH ACCELERATOR PEDAL DEPRESSED, PLACING LOWEST POINT ON ACCELERATOR ROD (A) .38 ABOVE TOE PANEL, & LEVER (H) ROTATED TO WIDE OPEN POSITION, ADJUST SWIVEL IN ROD (B) FOR FREE ENTRY OF ROD (B) INTO LEVER (H) BEFORE FIXING ROD (B) TO LEVER (H) IN CARBURETOR.
- 7 CHECK ADJUSTMENT BY RELEASING, THEN DEPRESSING ACCELERATOR PEDAL. CHECK LEVER (H) FOR WIDE OPEN POSITION. IF LEVER (H) WILL NOT REACH WIDE OPEN POSITION, REPEAT STEP 6.

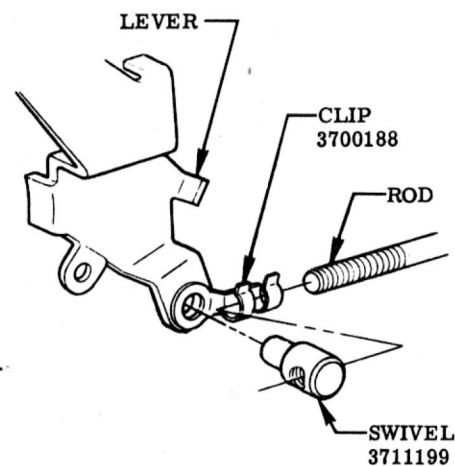

VIEW B

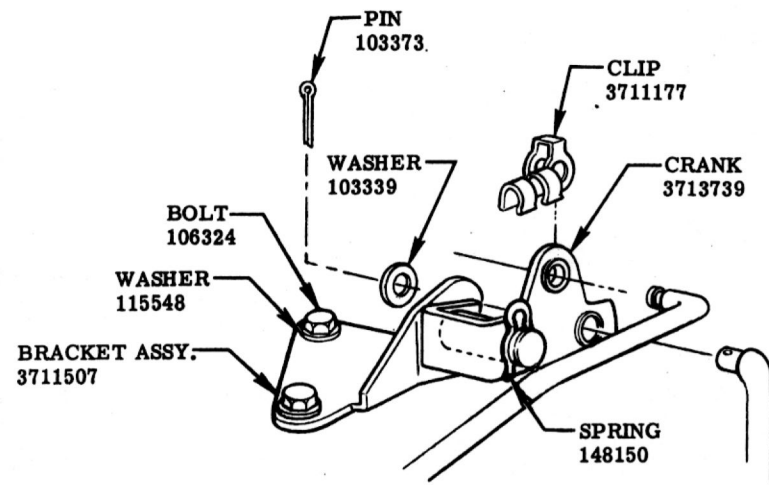

VIEW A

SEE LUBRICATION CHART SECTION 14
THROTTLE VALVE CONTROL

DATE		SYM.	REVISION RECORD	AUTH.	DR.	CK.	NAME	CORVETTE INSTRUCTION MANUAL		R. P. O.	SHEET
1-7-57	5		3736062 REMOVED	6073		F	REF.	DRAWN O.W.	CHECKED L.S.	313	5.00
8-6-56	4		WAS 3740660	3458		F					
7-13-56	3		REDRAWN & REVISED FOR 57	7356		F					
				5098	V		DATE	PART No.	3726900		
							9-15-55				