

WATERPROOF
WATERPROOF

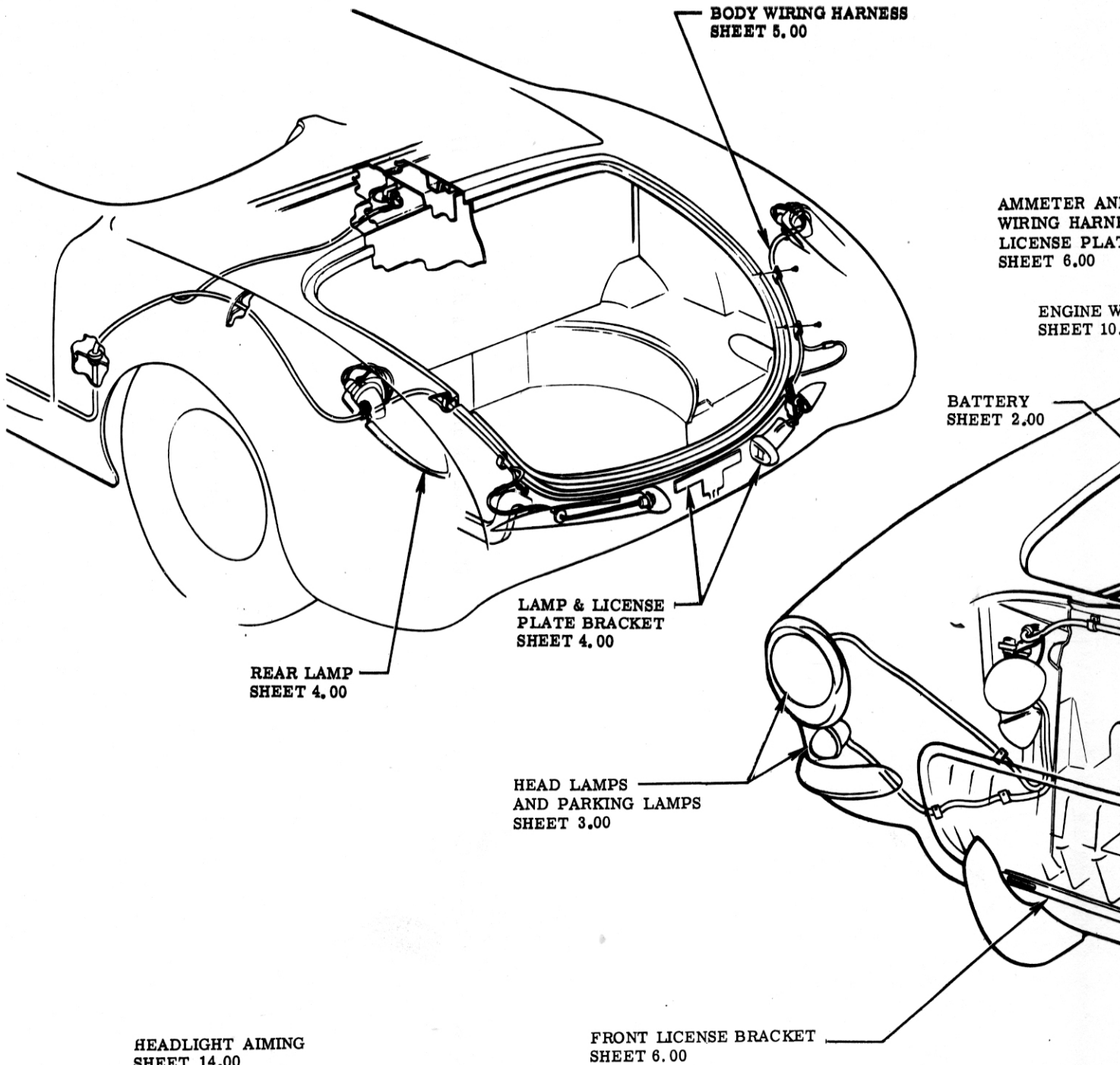



AMMETER AND
WIRING HARNESS
LICENSE PLATE
SHEET 6.00

ENGINE WIRING
SHEET 10.00

BATTERY
SHEET 2.00

HEADLIGHT AIMING
SHEET 14.00

WIRING DIAGRAM
SHEET 15.00

ELECTRICAL

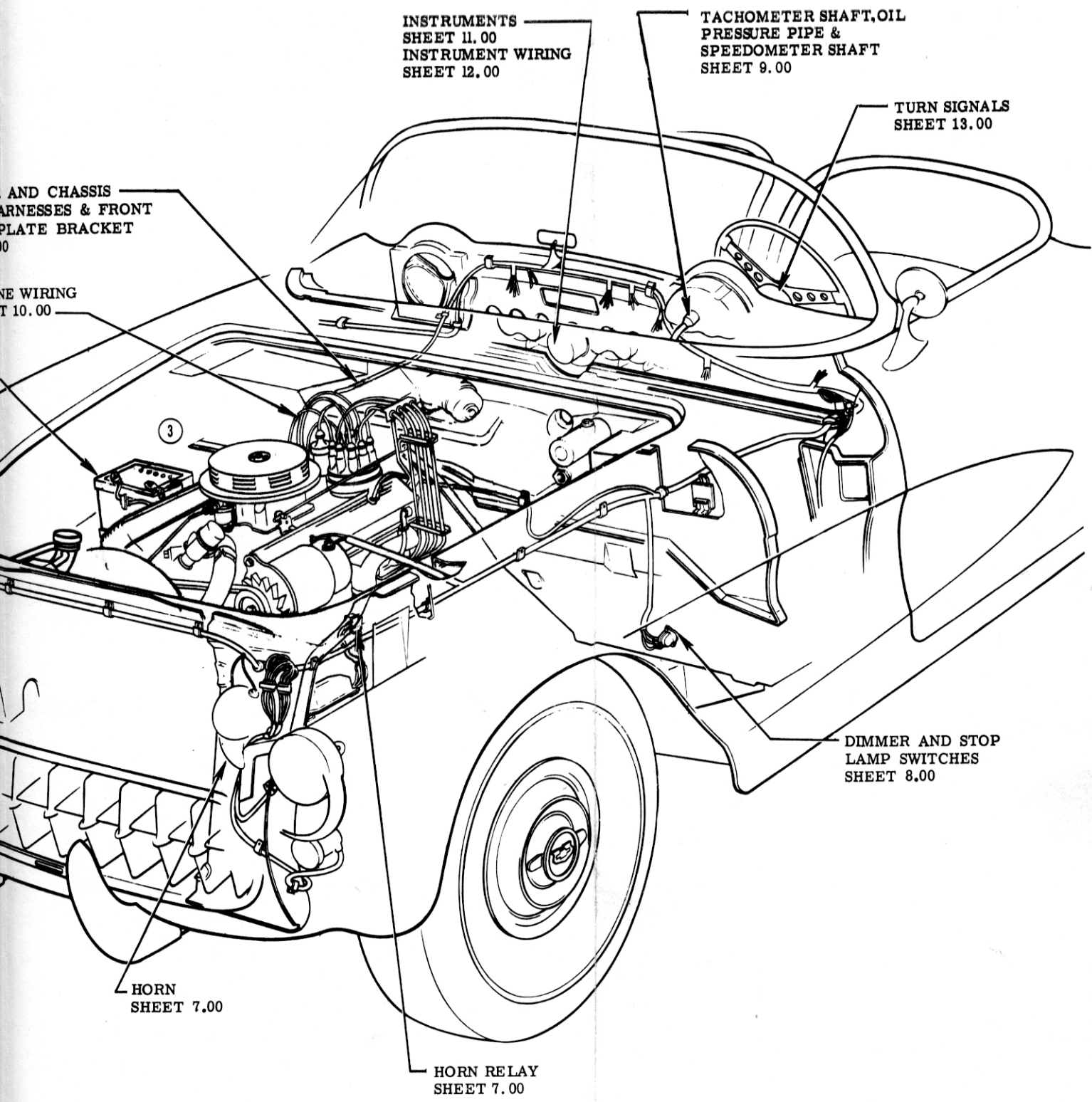

					NAME CORVETTE INSTRUCTION MANUAL				
					REF.	DRAWN W. S.	CHECKED L. S.	SECT.	SHEET
1-21-57	3	VIEW OF ENGINE REVISED		F	DATE 9-15-55	PART No. 3726900		12	1.00
6-4-56	2	REDRAWN & REVISED	9705	V F					
DATE	SYM.	REVISION RECORD	AUTH.	DR.	CK.				

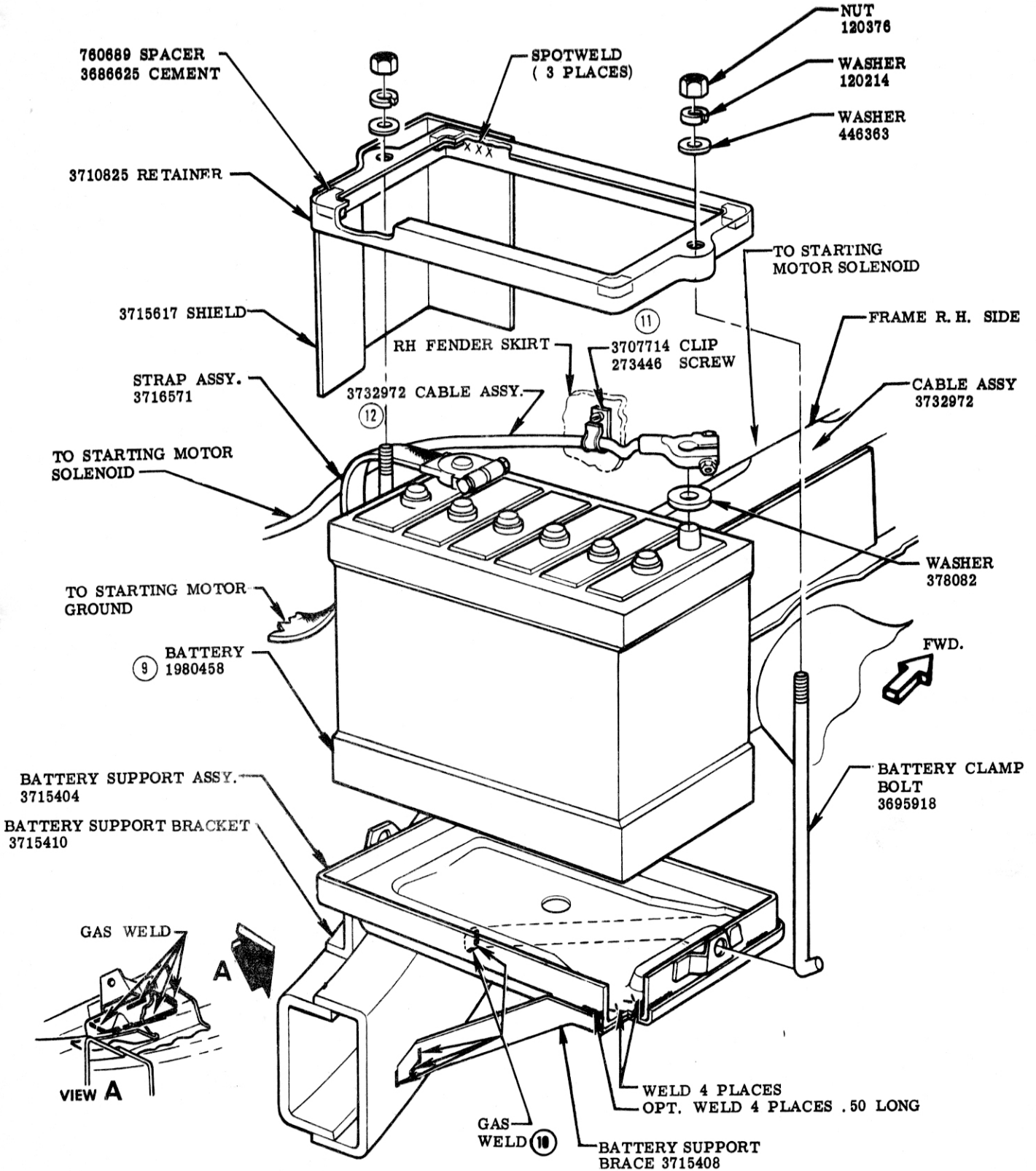

SEE LUBRICATION CHART SECTION 14

BATTERY

DATE	SYM.	REVISION RECORD	AUTH.	DR.	CK.	NAME	CORVETTE INSTRUCTION MANUAL					
1-21-57	12	DIRECTION OF CABLE REVISED				F						
10-11-56	11	PARTS ADDED	231			F	REF.	DRAWN R. H.	CHECKED N. D.	SECT.	SHEET	
	9	WAS 1890587				F				12	2.00	
9-5-56	8	REDRAWN	3416				DATE 9-15-55	PART No. 3726900				

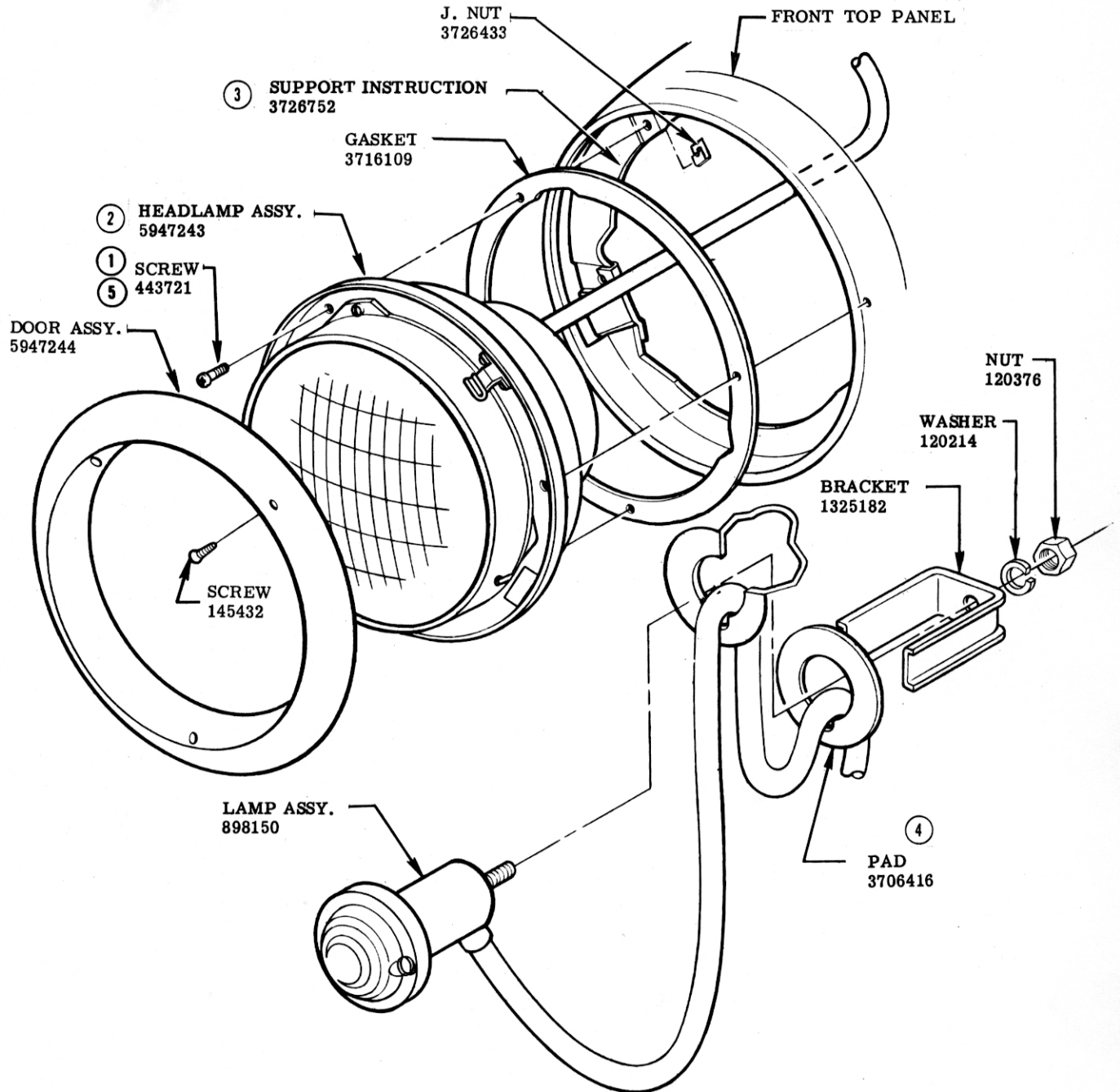

HEADLAMP & PARKING LAMP

10-11-56	5	WAS 127884	4320		F	NAME CORVETTE INSTRUCTION MANUAL				
	4	PAD RELOCATED		V	F	REF.	DRAWN J.J.	CHECKED N.D.	SECT.	SHEET
	3	PART NO. ADDED	5960			DATE 9-15-55	PART No. 3726900		12	3.00
	2	WAS 5946154								
2-2-56	1	WAS 273445								
DATE	SYM.	REVISION RECORD	AUTH.	DR.	CK.					

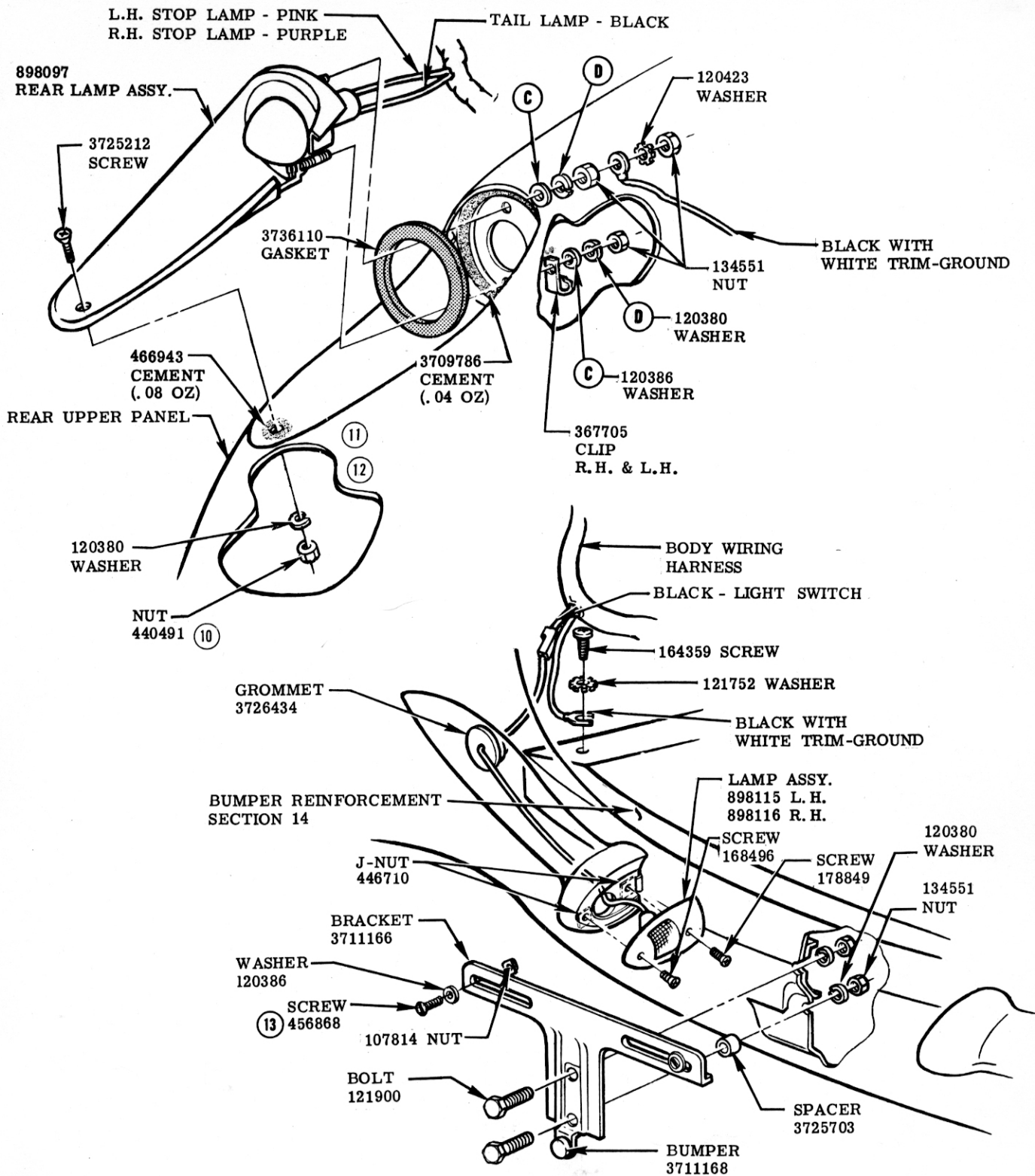

REAR LAMP, LICENSE LAMP & LICENSE PLATE BRACKET

10-11-56	13	WAS 120628	4320		F	NAME CORVETTE INSTRUCTION MANUAL				
	12	120392 WASHER REMOVED			F	REF.	DRAWN J.J.	CHECKED L.S.	SECT.	SHEET
	11	446354 WASHER REMOVED							12	4.00
	10	WAS 134551								
8-6-56	9	REDRAWN	3088			DATE 9-15-55	PART No. 3726900			
DATE	SYM.	REVISION RECORD	AUTH.	DR.	CK.					

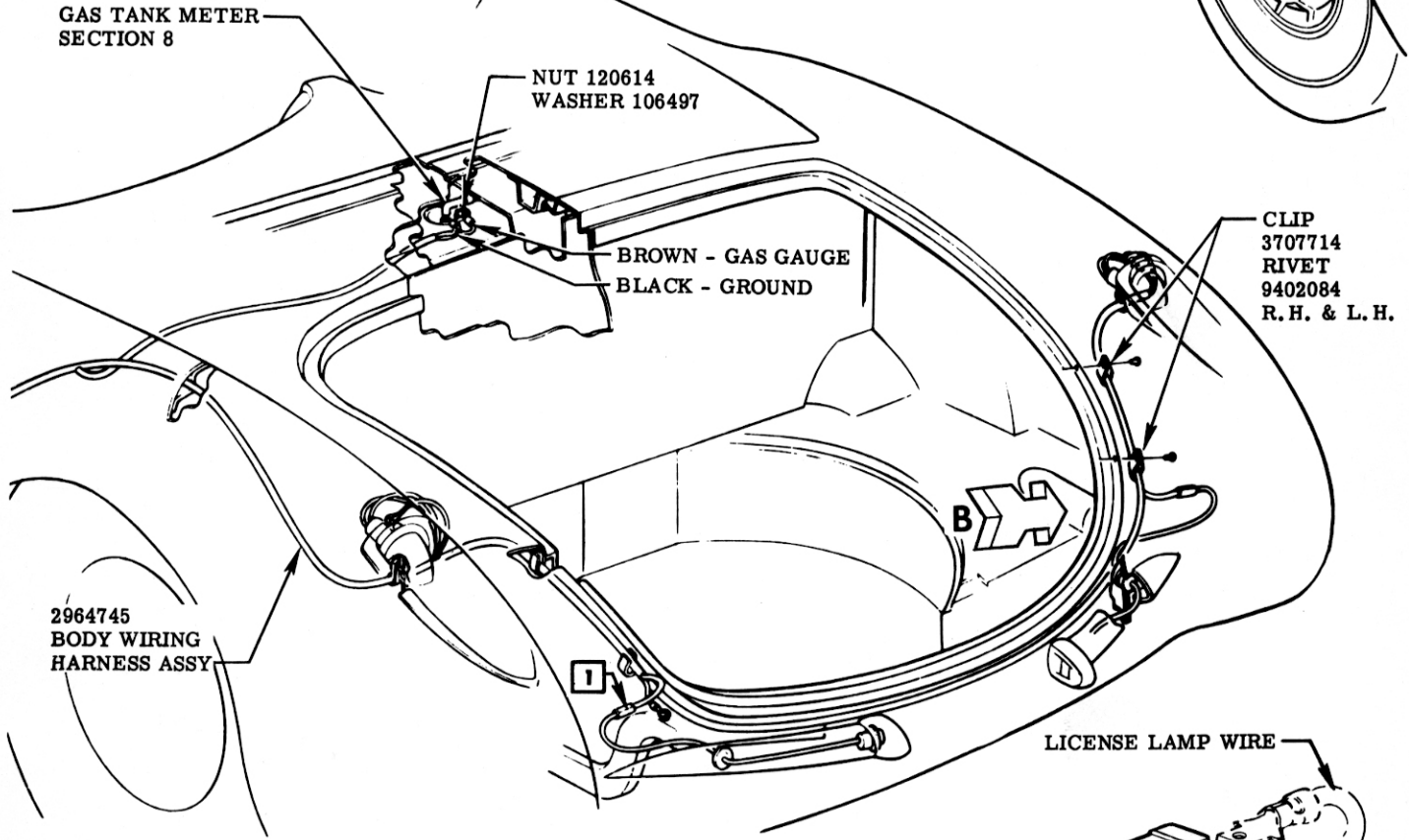
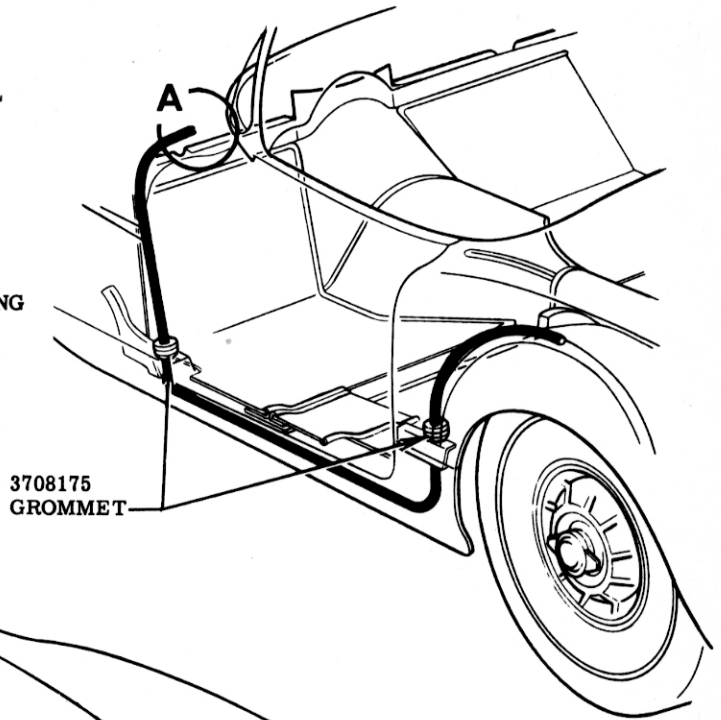
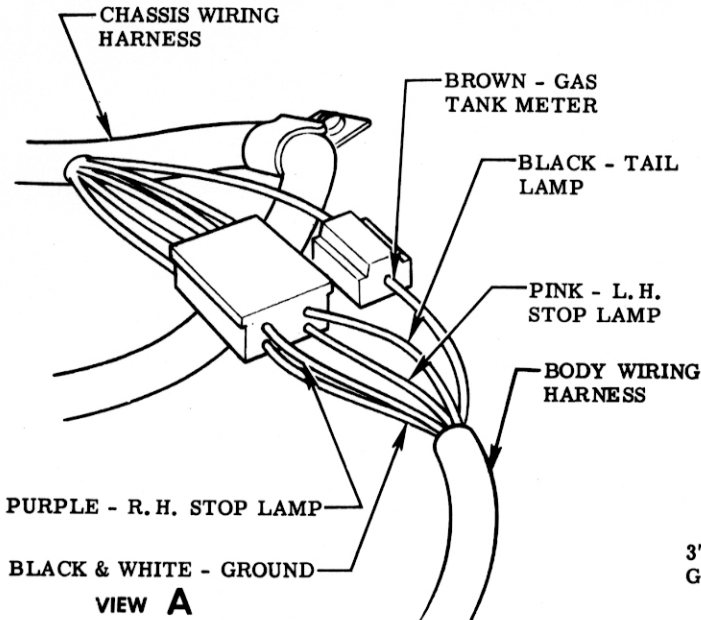

1 5297952 CONNECTOR BODY, PART OF BODY WIRING HARNESS ASSY, SHIPPED LOOSE.

PRESS INTO CONNECTOR BODY UNTIL TANG LOCKS IN PLACE

BODY WIRING HARNESS ASSY

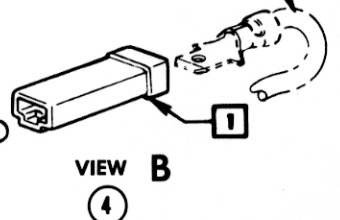

BODY WIRING HARNESS

						CORVETTE INSTRUCTION MANUAL				
DATE	SYM.	REVISION RECORD	AUTH.	DR.	CK.	REF.	DRAWN W. S.	CHECKED L. S.	SECT.	SHEET
3-25-57	4	VIEW ADDED	7938	V	F					
6-4-56	3	REDRAWN & REVISED	9705	V	F	DATE	PART No.		12	5.00
						9-15-55	3726900			

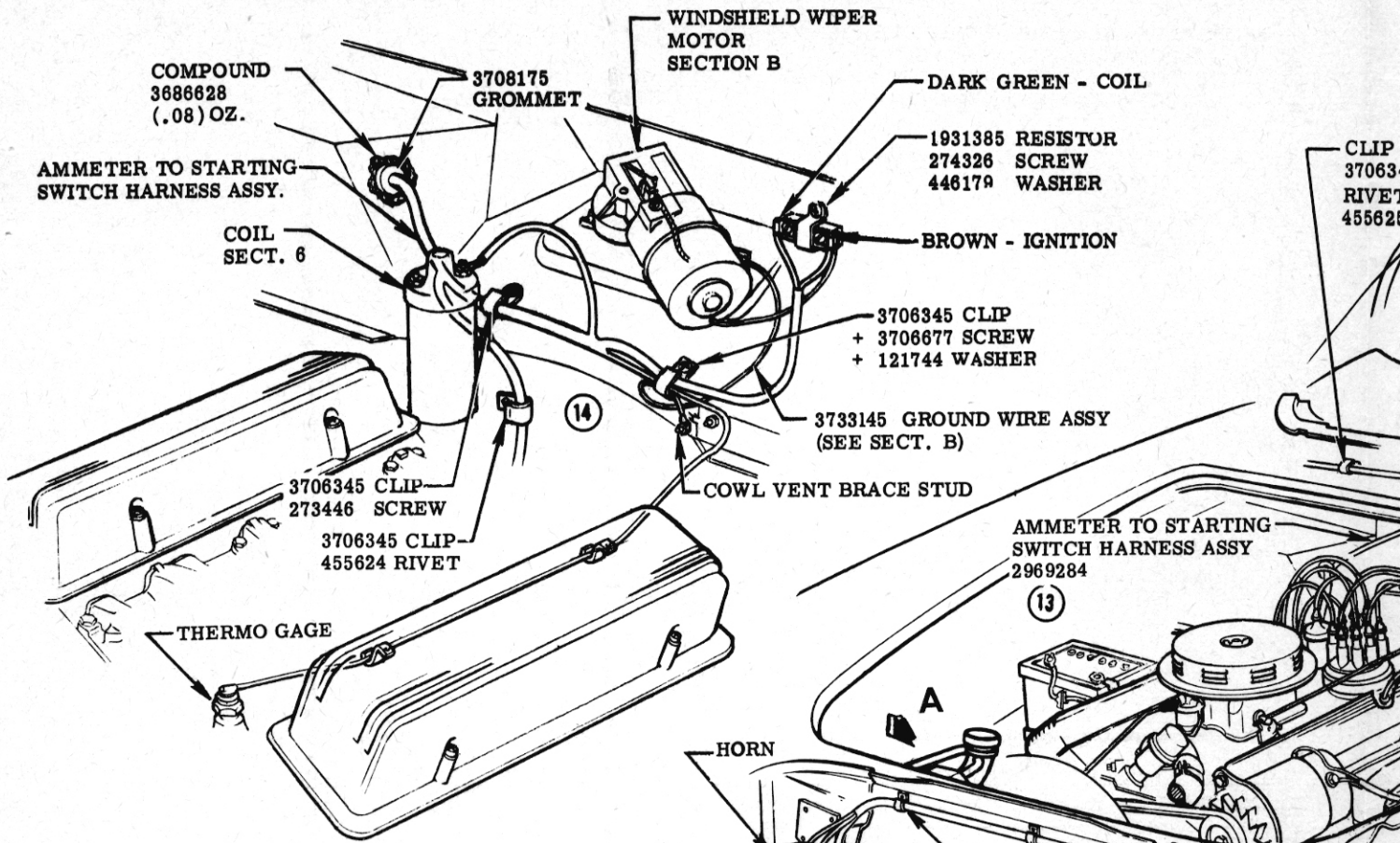

VIEW C

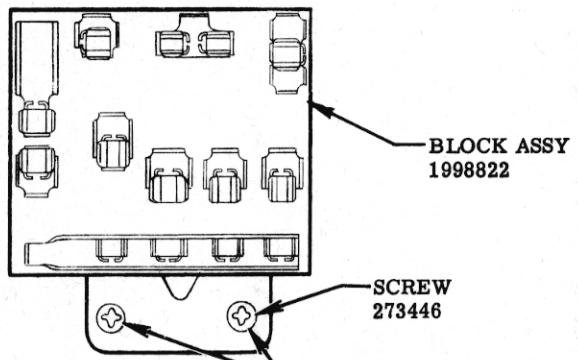

VIEW D

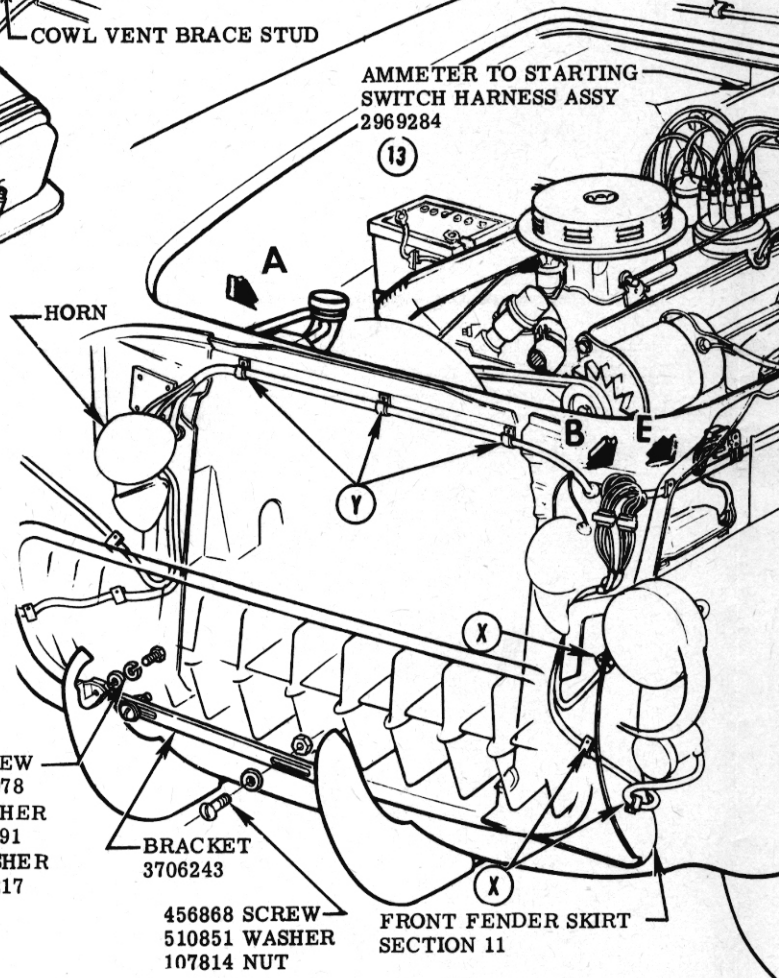

(X) CLIP 3707714
SCREW 273446

(Y) CLIP 36770

AMMETER & CHASSIS WIRING HARNESSSES & FRONT LICENSE PLATE BRACKET

367705 CLIP, HELD IN PLACE BY ATTACHING PARTS,
(RH DEFROSTER ESCUTCHEON, SECT. B)
ROUTE HARNESS THRU CLIP, AND OVER HOOD
LATCH AND W/S WIPER CABLES.

CLIP
3706345
RIVET
55625

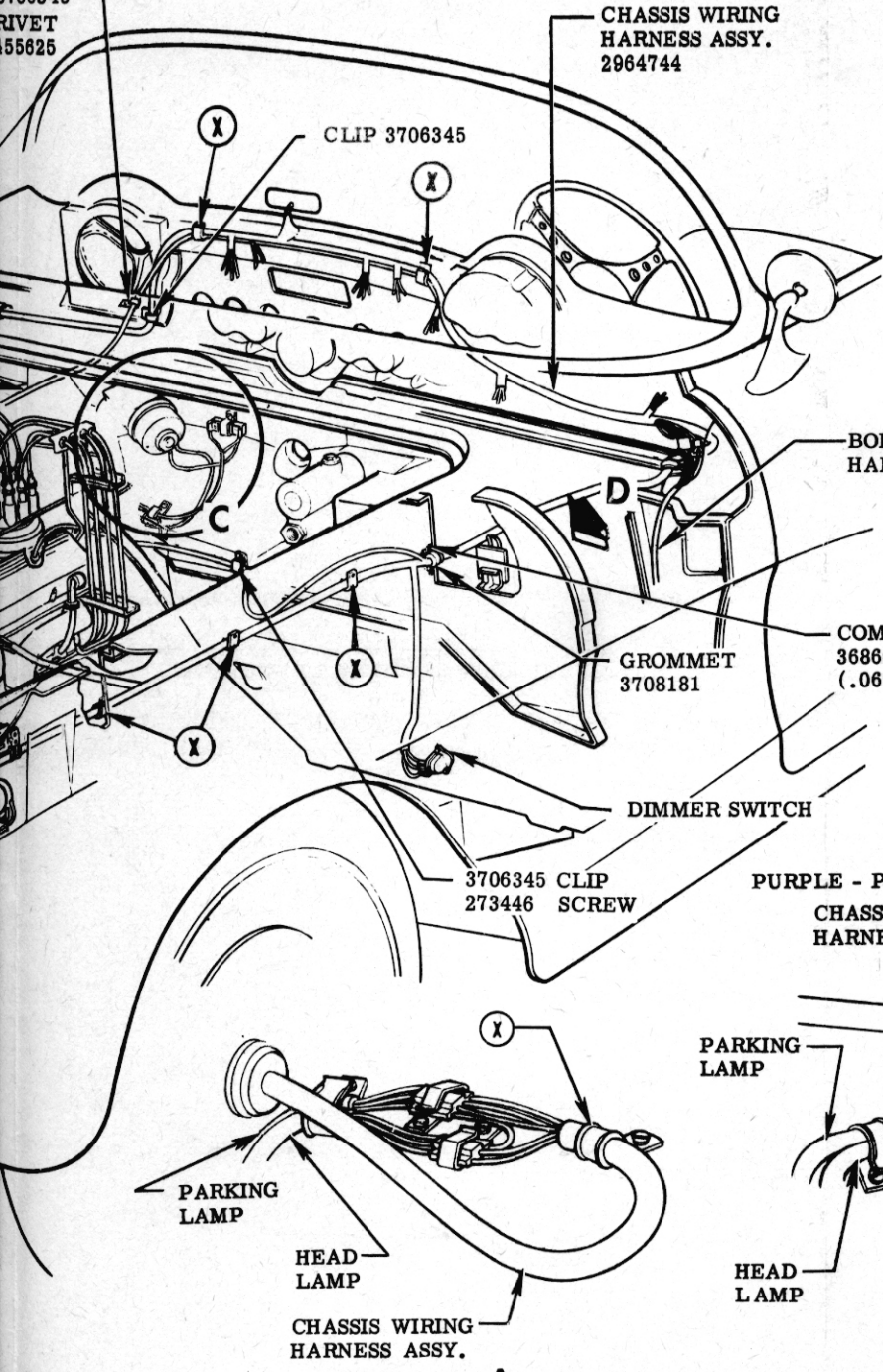

VIEW A
R.H. ONLY
(IDENTICAL TO VIEW B
EXCEPT AS SHOWN)

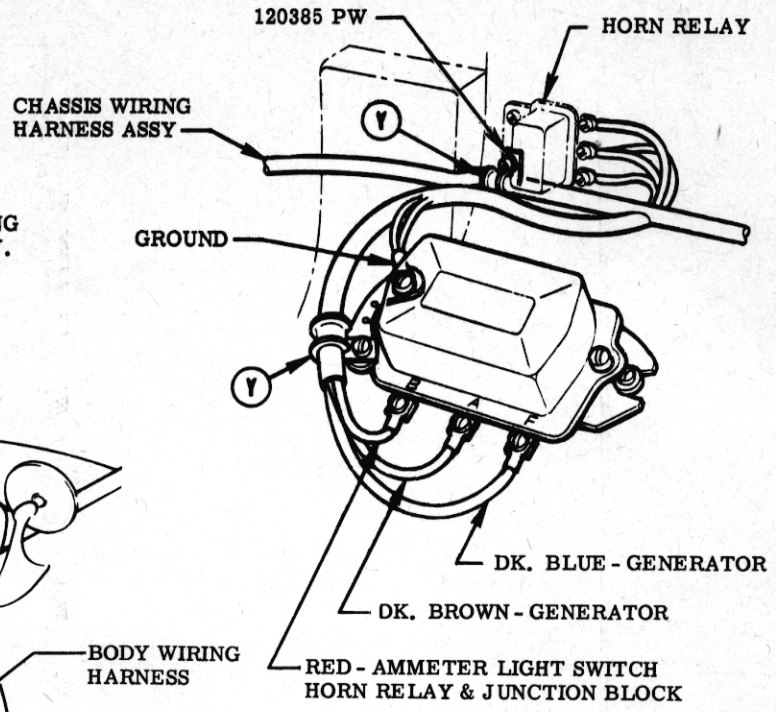

VIEW E

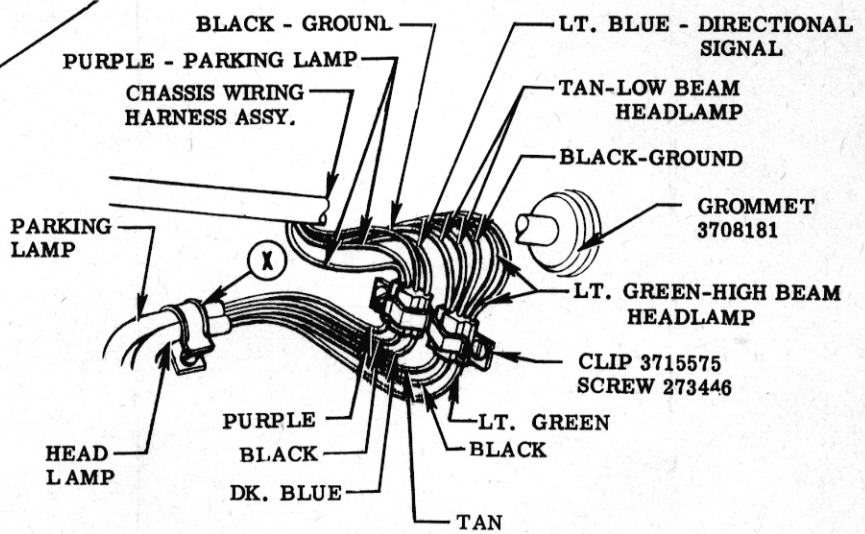

VIEW B
L.H. ONLY

						NAME CORVETTE INSTRUCTION MANUAL				
DATE	SYM.	REVISION RECORD	AUTH.	DR.	CK.	REF.	DRAWN W.S.	CHECKED L.S.	SECT.	SHEET
	14	HARNESS REROUTED								
3-15-57	13	WAS 2968411	325	V	F					
1-21-57	12	REDRAWN & REVISED	6145	231	V F					
						DATE 9-15-55	PART No. 3726900		12	6.00

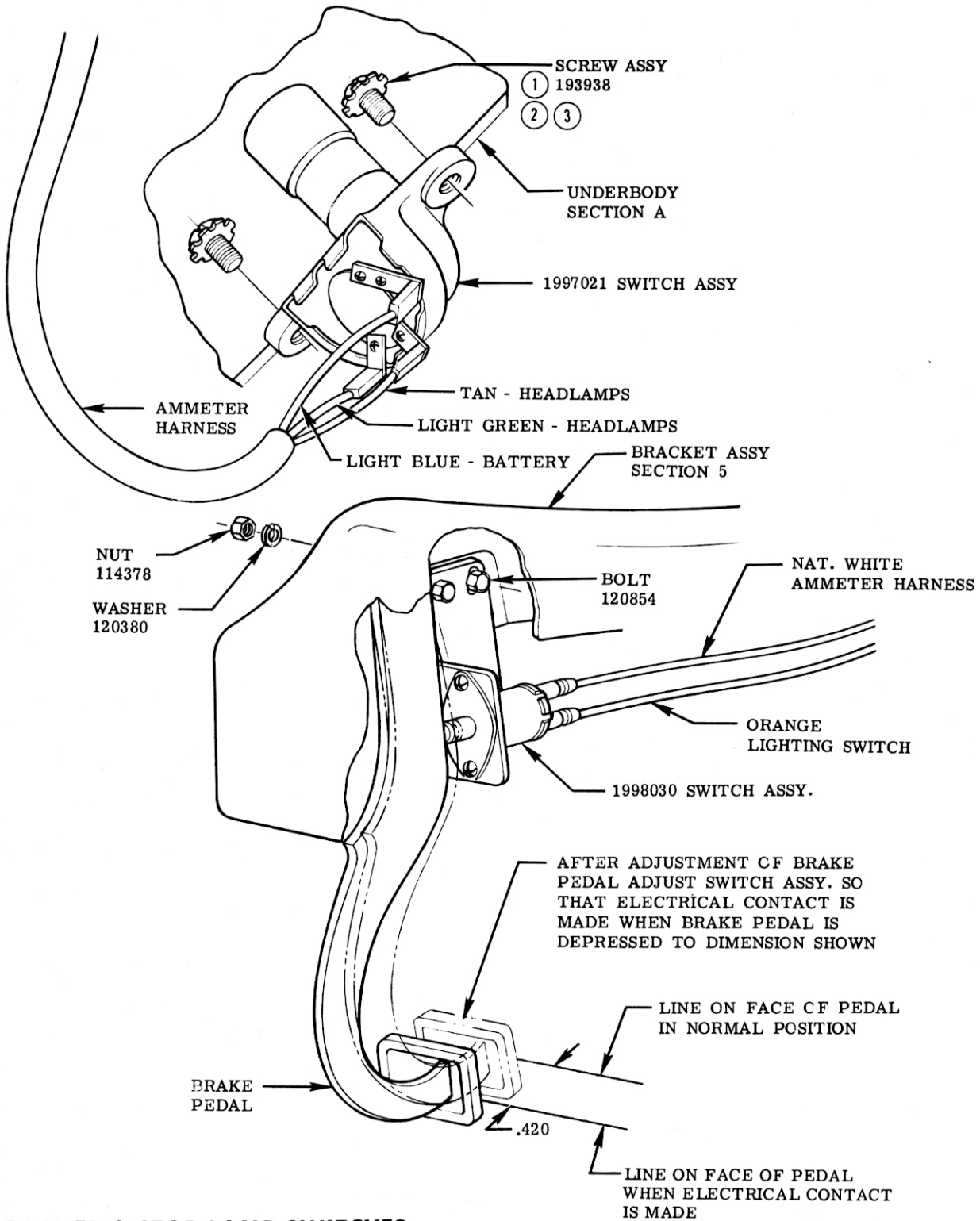

DIMMER & STOP LAMP SWITCHES

REVISION RECORD						CORVETTE INSTRUCTION MANUAL				
DATE	SYM.	REVISION	AUTH.	DR.	CK.	REF.	DRAWN	CHECKED	SECT.	SHEET
11-5-56	3	106972 BOLT WITH 103319 LW			F		J. J.	L. S.	12	8.00
		OPTION REMOVED	5290							
7-16-56	2	106972-103319 OPT. ADDED	9578	V	F					
3-6-56	1	WAS 455489	8284		F	DATE	PART No.			
						9-15-55	3726900			

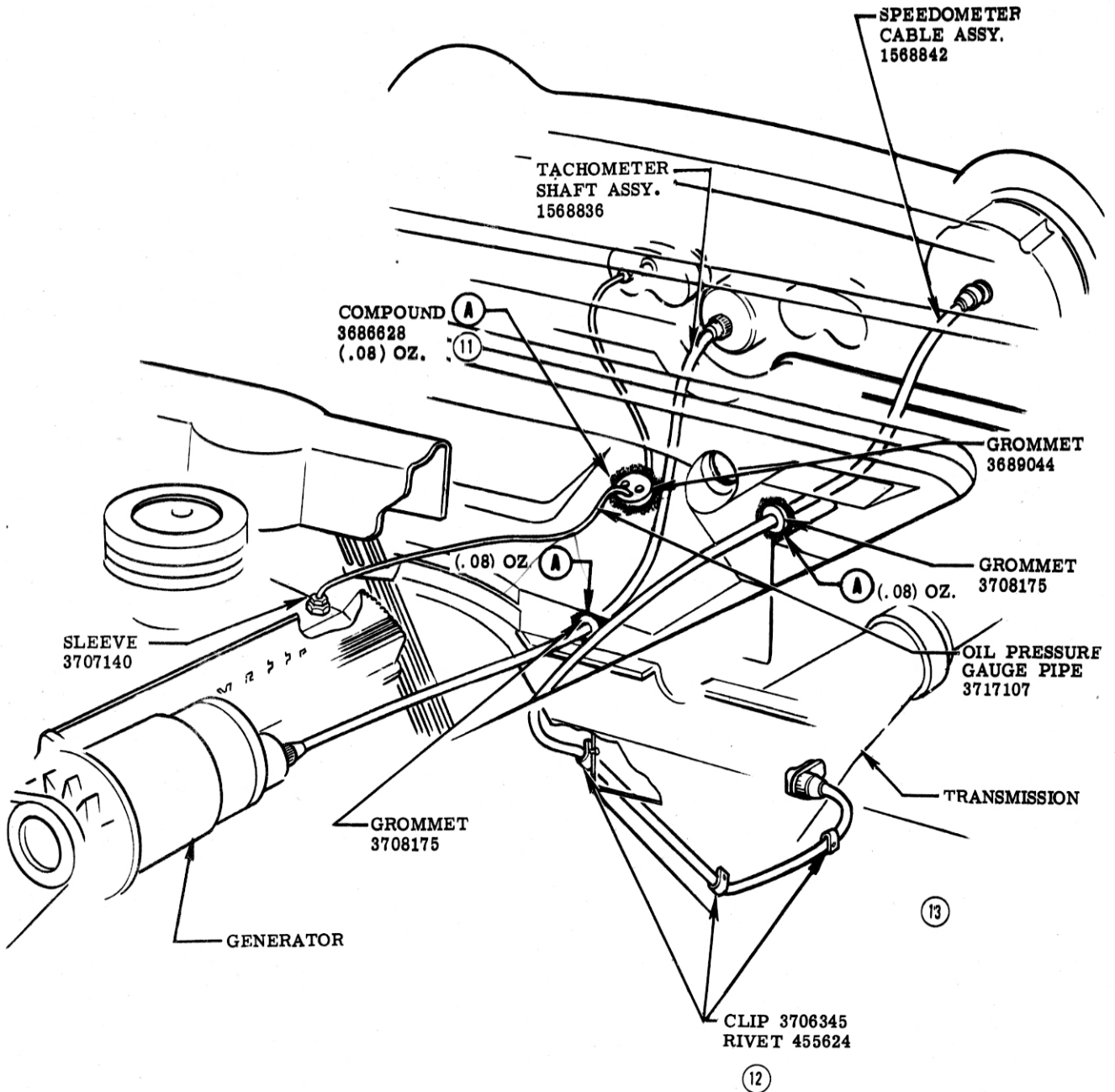

TACHOMETER SHAFT, OIL PRESSURE PIPE & SPEEDOMETER SHAFT

					NAME CORVETTE INSTRUCTION MANUAL				
	13	NOTE REMOVED			REF.	DRAWN J.J.	CHECKED L.S.	SECT.	SHEET
1-21-57	12	NOTE REMOVED						12	9.00
	11	PART ADDED			DATE	PART No.			
11-13-56	10	REDRAWN	4059	V	9-15-55	3726900			
DATE	SYM.	REVISION RECORD	AUTH.	DR.	CK.				

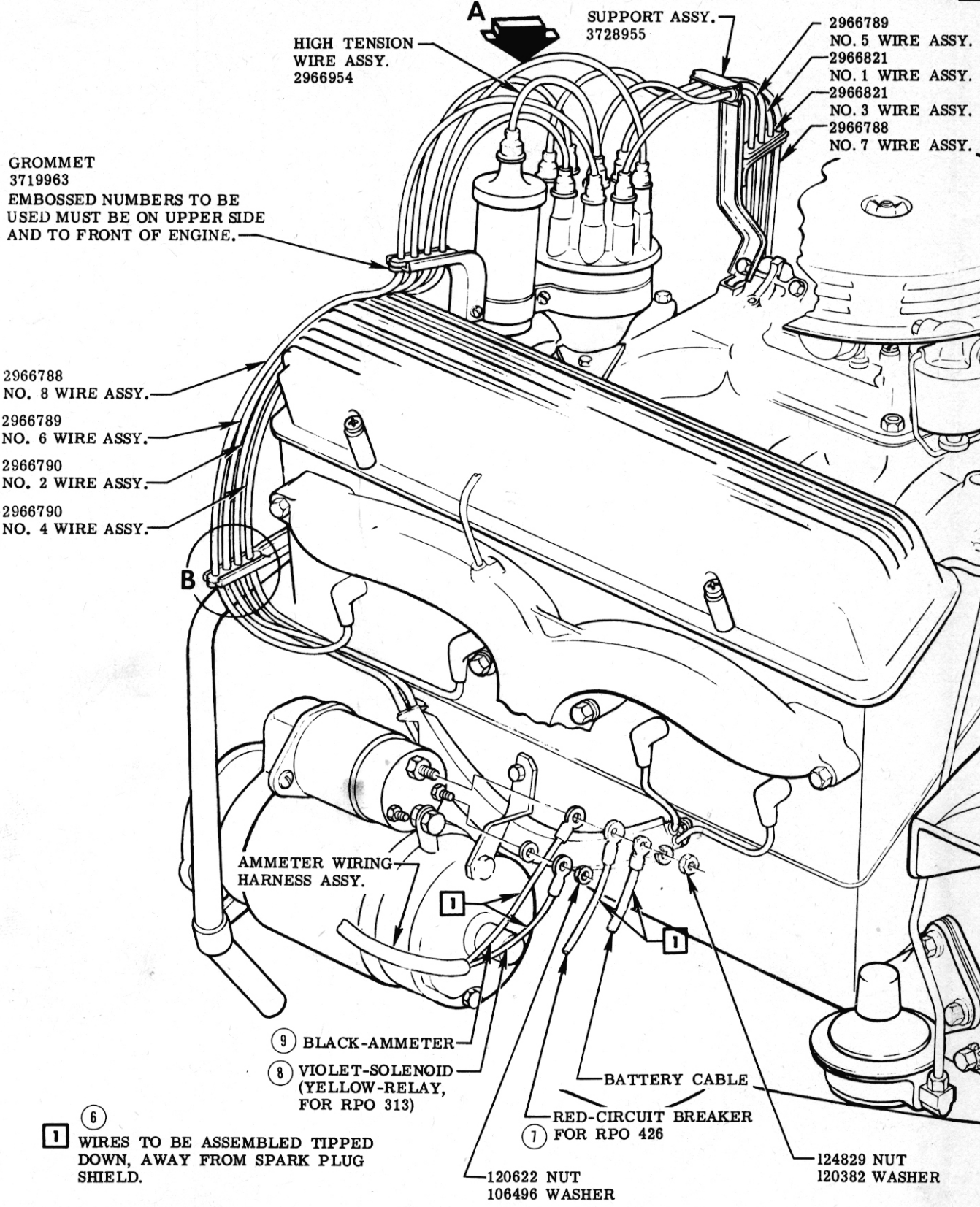

GROMMET
3719963
EMBOSSED NUMBERS TO BE
USED MUST BE ON UPPER SIDE
AND TO FRONT OF ENGINE.

- 2966788
NO. 8 WIRE ASSY.
- 2966789
NO. 6 WIRE ASSY.
- 2966790
NO. 2 WIRE ASSY.
- 2966790
NO. 4 WIRE ASSY.

- 2966789
NO. 5 WIRE ASSY.
- 2966821
NO. 1 WIRE ASSY.
- 2966821
NO. 3 WIRE ASSY.
- 2966788
NO. 7 WIRE ASSY.

AMMETER WIRING
HARNESS ASSY.

- 9 BLACK-AMMETER
- 8 VIOLET-SOLENOID
(YELLOW-RELAY,
FOR RPO 313)

- 7 RED-CIRCUIT BREAKER
FOR RPO 426

6
1 WIRES TO BE ASSEMBLED TIPPED
DOWN, AWAY FROM SPARK PLUG
SHIELD.

120622 NUT
106496 WASHER

124829 NUT
120382 WASHER

ENGINE WIRING



GENERAL MOTORS CORPORATION

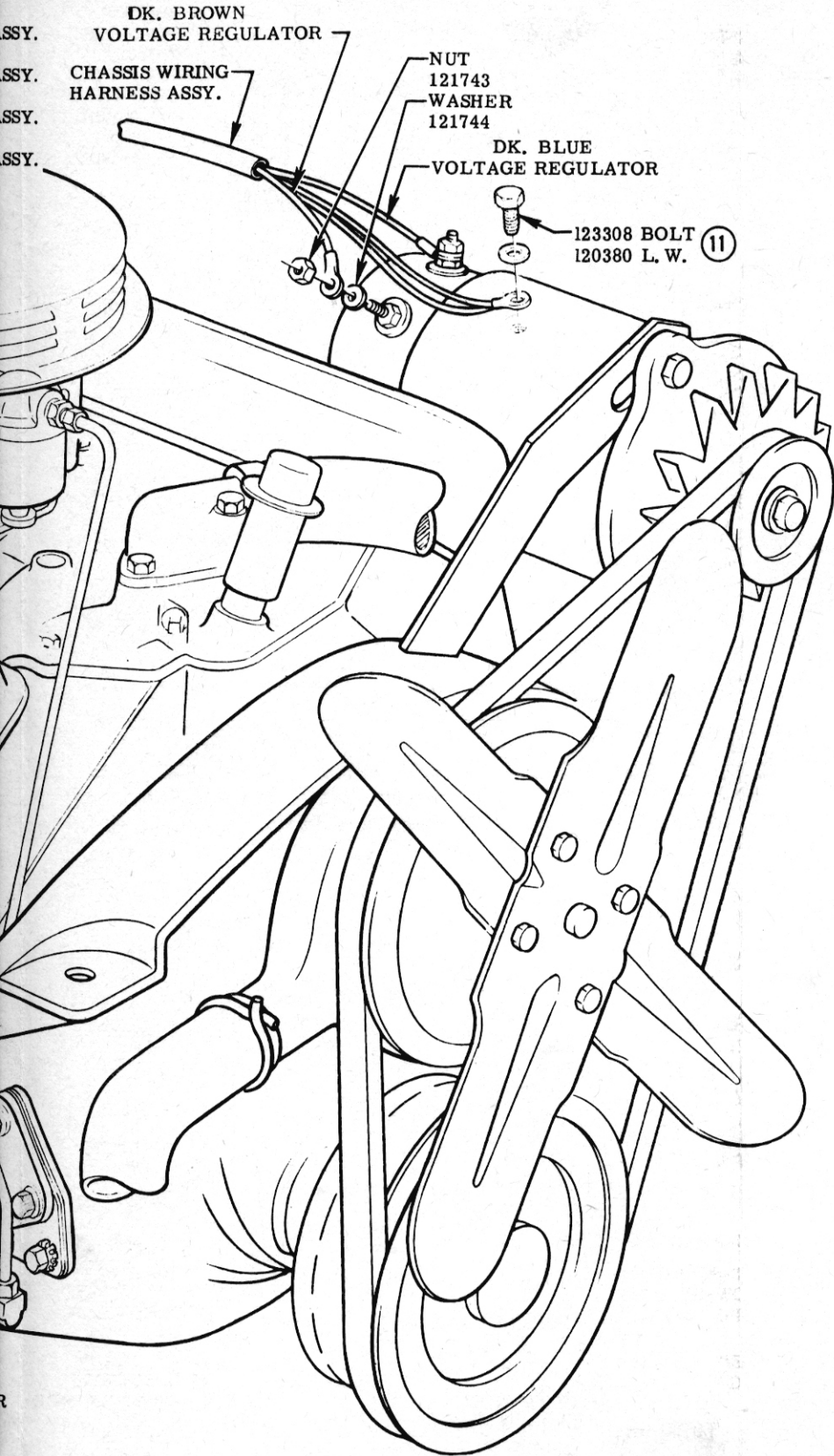

DISTRIBUTOR CAP CLIPS ON LINE PERPENDICULAR TO AXIS OF ENGINE.

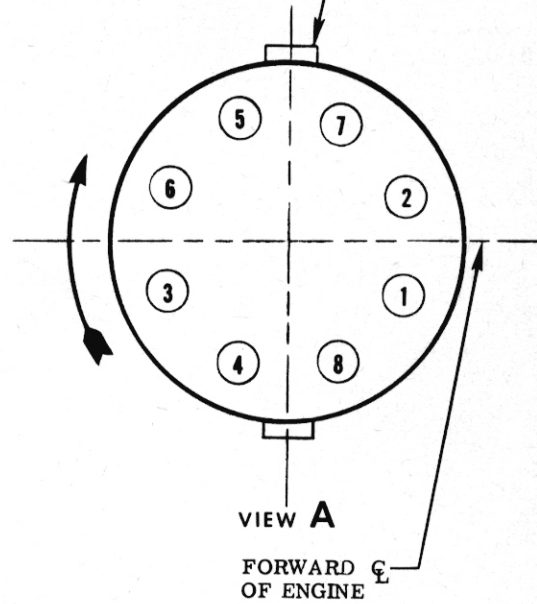

SCREW ASSY 193938
 BOLT 106972
 LW 103319

OPT

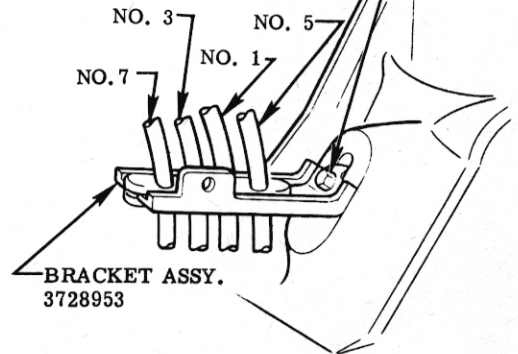

B L.H. ONLY

					NAME CORVETTE INSTRUCTION MANUAL				
					REF.	DRAWN W.S.	CHECKED L.S.	SECT.	SHEET
	11	PARTS ADDED		F				12	10.00
4-22-57	10	REDRAWN	7717	V	DATE 9-15-55	PART No. 3726900			
DATE	SYM.	REVISION RECORD	AUTH.	DR.	CK.				

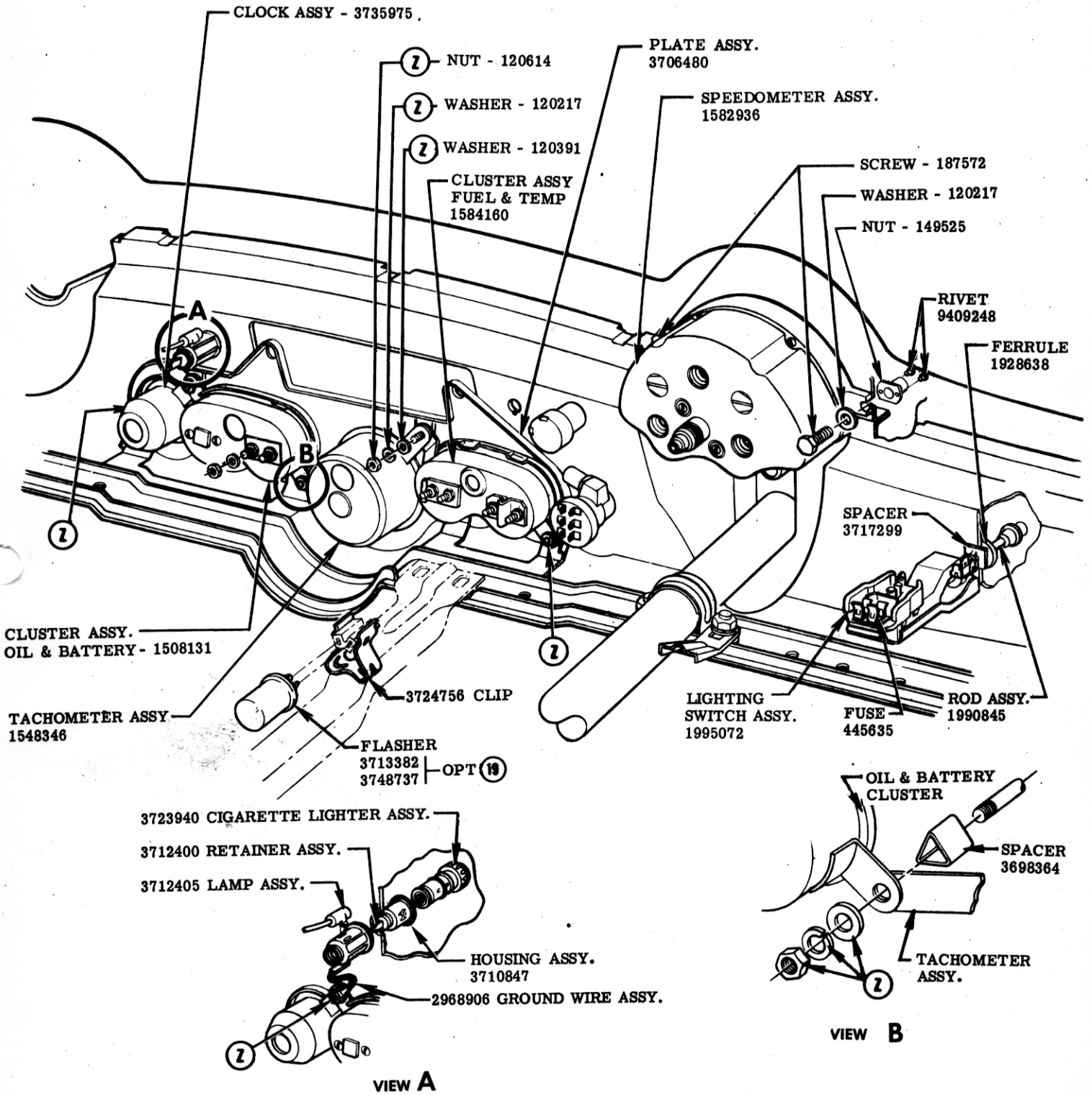

INSTRUMENTS

					CORVETTE INSTRUCTION MANUAL				
					NAME	DRAWN O.W.	CHECKED L.S.	SECT.	SHEET
	19	WAS 3713382-3715248 OPT.		F	REF.			12	11.00
4-9-57	18	REDRAWN	8881	V	DATE	PART No.	3726900		
DATE	SYM.	REVISION RECORD	AUTH.	DR.	CK.				

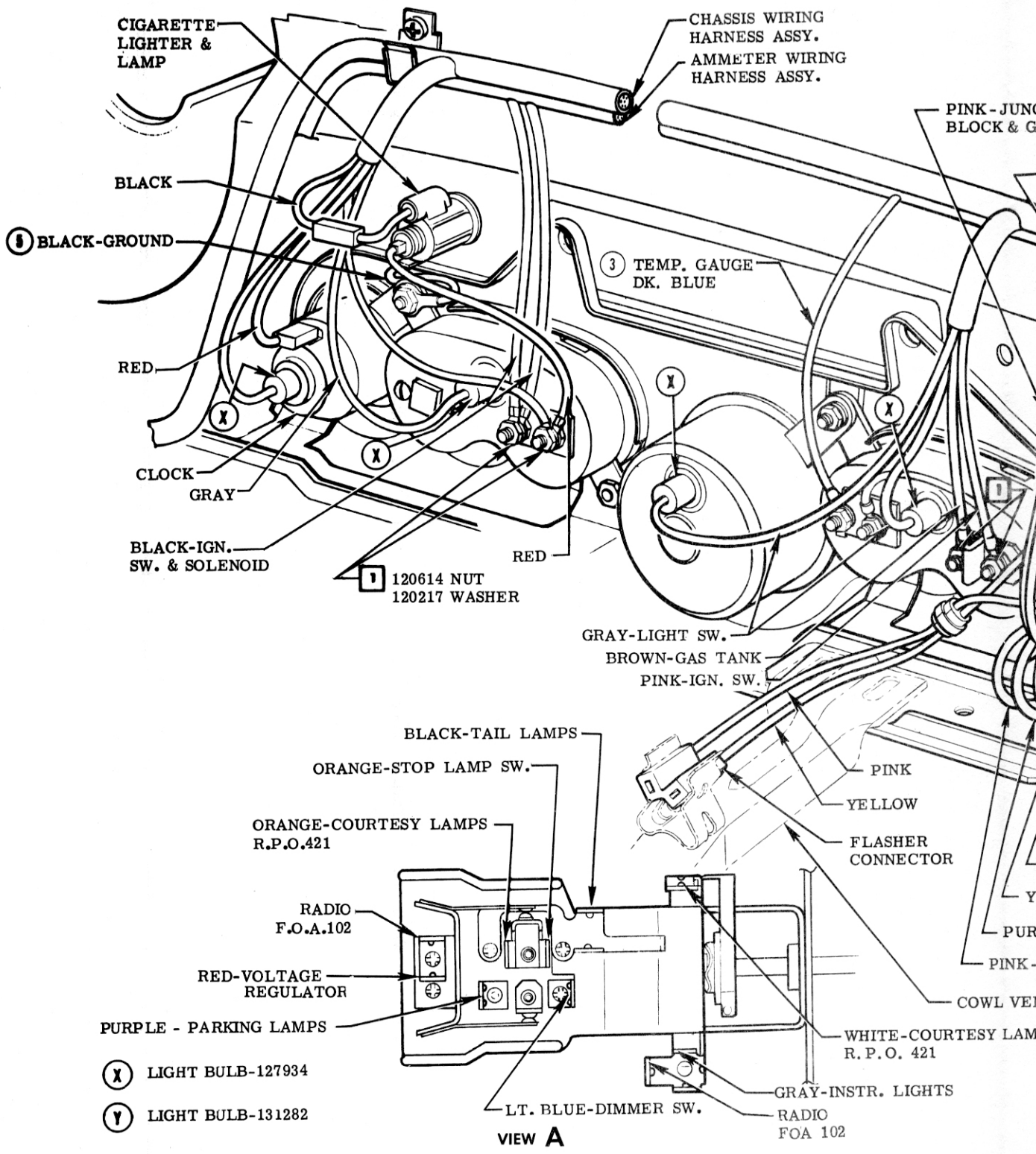

INSTRUMENT WIRING



GENERAL MOTORS CORPORATION

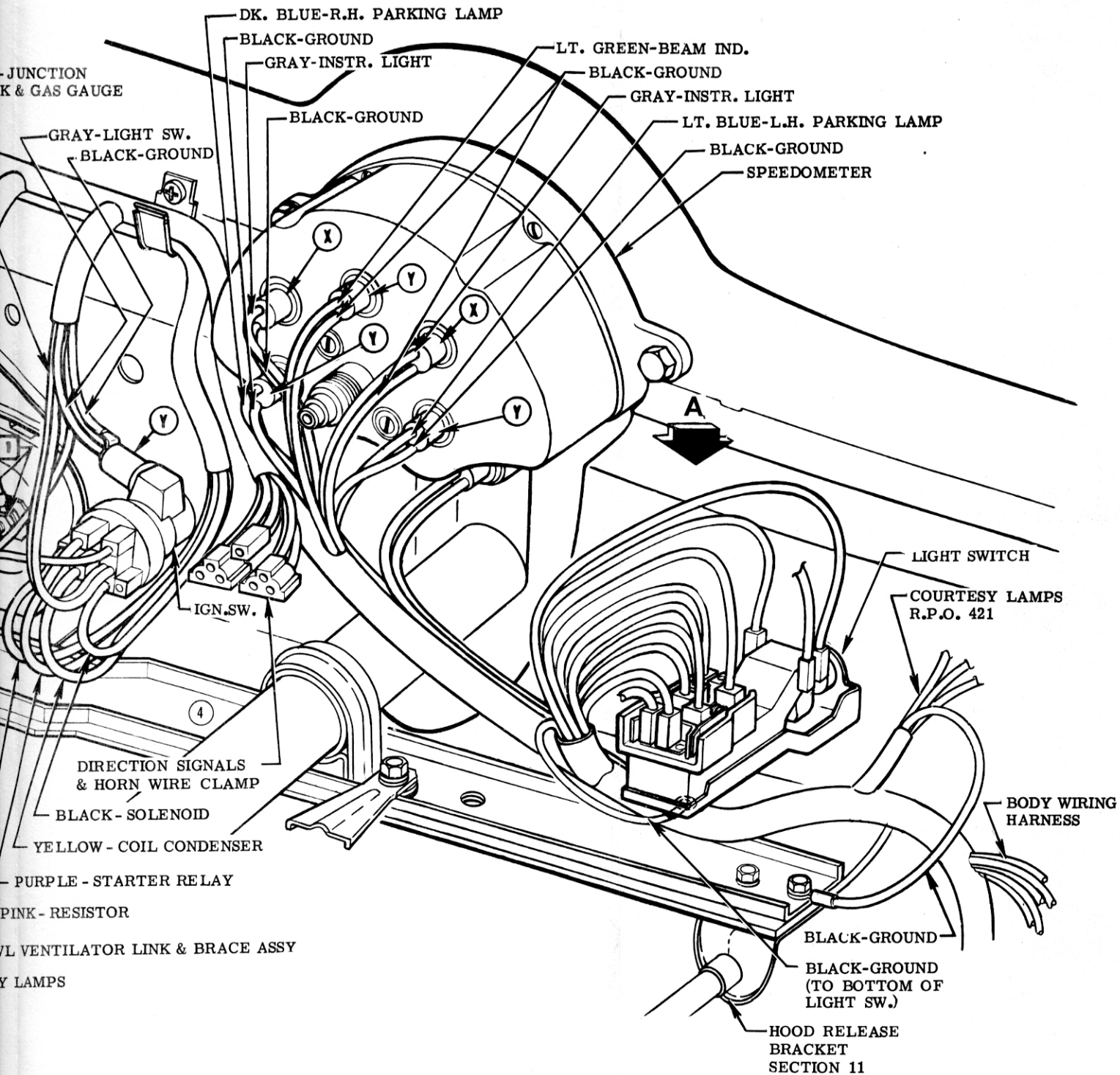

					CORVETTE INSTRUCTION MANUAL					
1-28-57	5	WAS PART OF HARNESS ASSY.	5902	V	F	REF.	DRAWN J. J.	CHECKED L. S.	SECT.	SHEET
12-18-56	4	FLASHER CONN. RELOCATED	185	V	F					
10-11-56	3	WAS COLOR-ORANGE	4049		F	DATE	PART No.	12	12.00	
6-4-56	2	REDRAWN & REVISED	9705	V	F					
DATE	SYM.	REVISION RECORD	AUTH.	DR.	CK.	9-15-55	3726900			

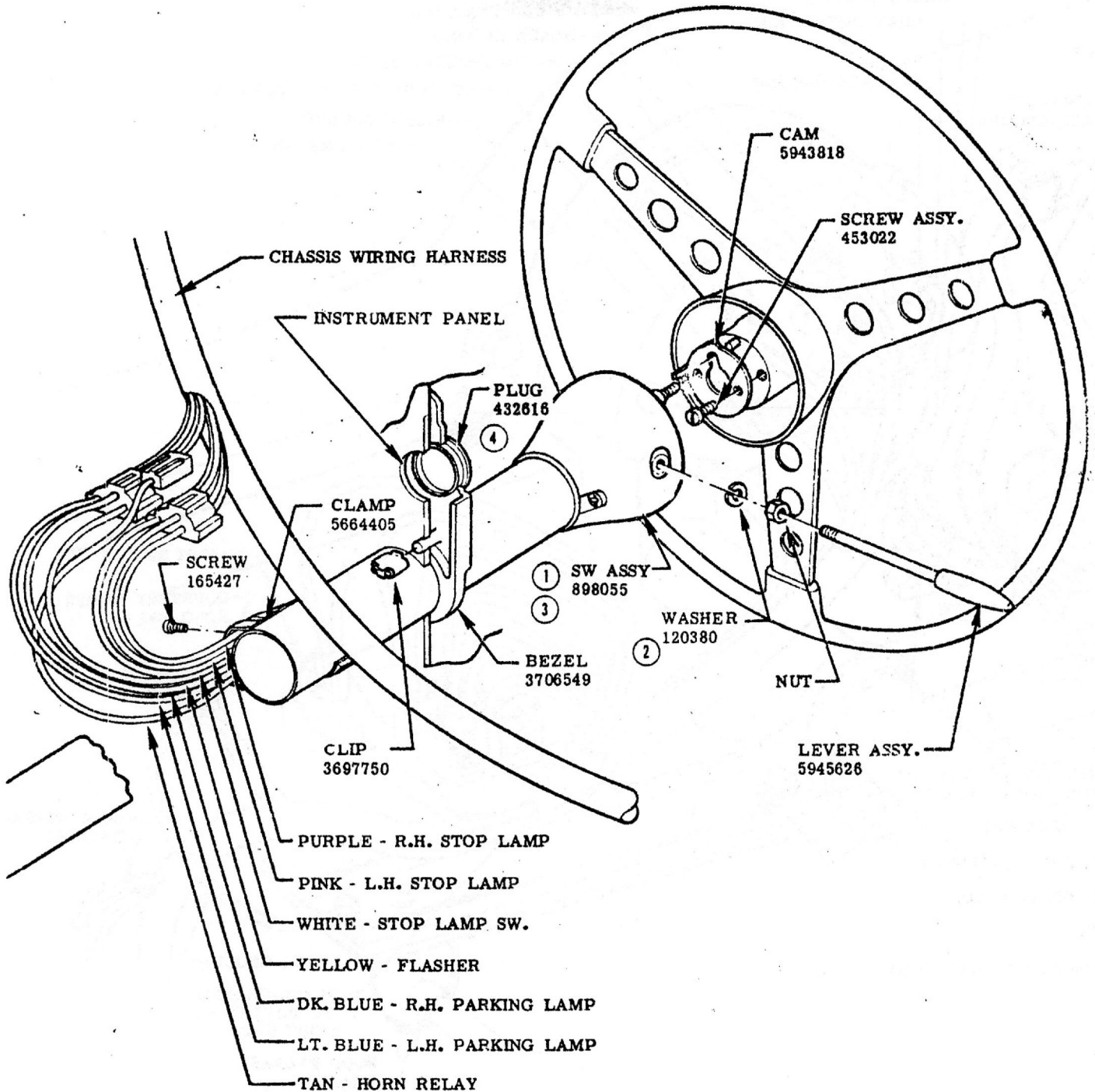

DIRECTIONAL SIGNALS & HORN WIRE CLAMP

						CORVETTE INSTRUCTION MANUAL				
3-12-56	4	NO. ADDED	8148		F	REF.	DRAWN O.W.	CHECKED L.S.	SECT.	SHEET
2-27-56	3	WAS 898056	6764		F				12	13.00
	2	NO. ADDED	—		F					
1-16-56	1	WAS 897763	5287			DATE	PART No.			
DATE	SYM.	REVISION RECORD	AUTH.	DR.	CK.	9-15-55	3726900			

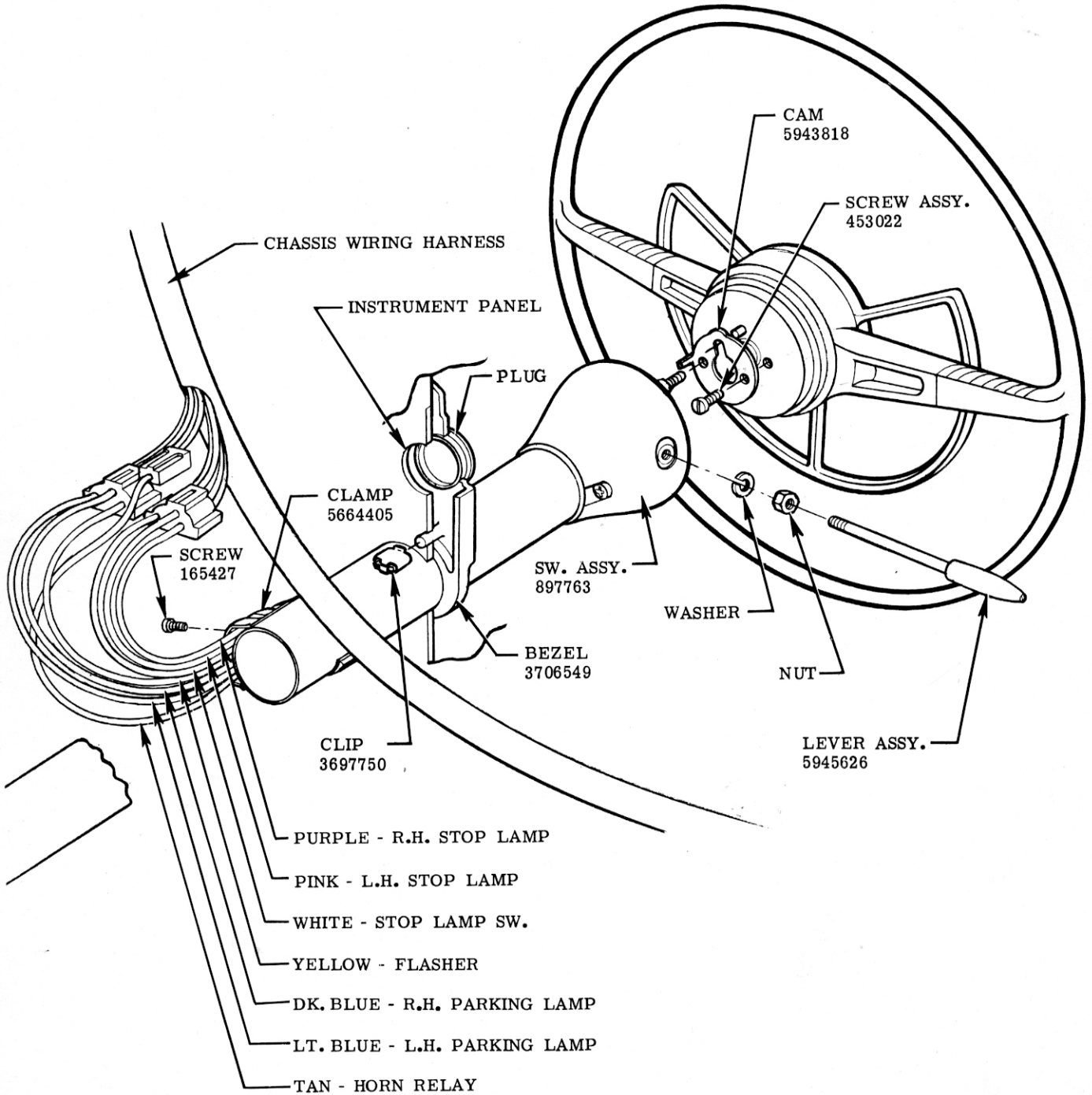

DIRECTIONAL SIGNALS & HORN WIRE CLAMP

						NAME	CORVETTE INSTRUCTION MANUAL			
						REF.	DRAWN O. W.	CHECKED L. S.	SECT.	SHEET
						DATE	PART No.		12	13.00
DATE	SYM.	REVISION RECORD	AUTH.	DR.	CK.	9-15-55	3726900			



BEAM AIM SHALL BE CHECKED WITH NO LOAD IN THE VEHICLE OTHER THAN THE DRIVER IN THE FRONT SEAT

ADJUSTMENTS TO BE MADE WITH UPPER BEAM ON. EACH LAMP AIMED INDEPENDENTLY WITH OTHER LAMP COVERED

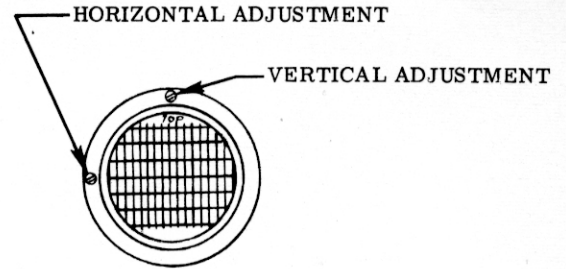

MAKE ADJUSTMENTS BEFORE ASSEMBLING LAMP DOORS

THIS DIM MUST BE HELD FROM FRONT OF HEADLAMP TO FRONT FACE OF SCREEN

AIM VERTICALLY SO THAT CENTER OF HOT SPOT IS 2.0 INCHES BELOW CENTER OF LAMP ON CAR WITHIN ± 1.5 INCHES

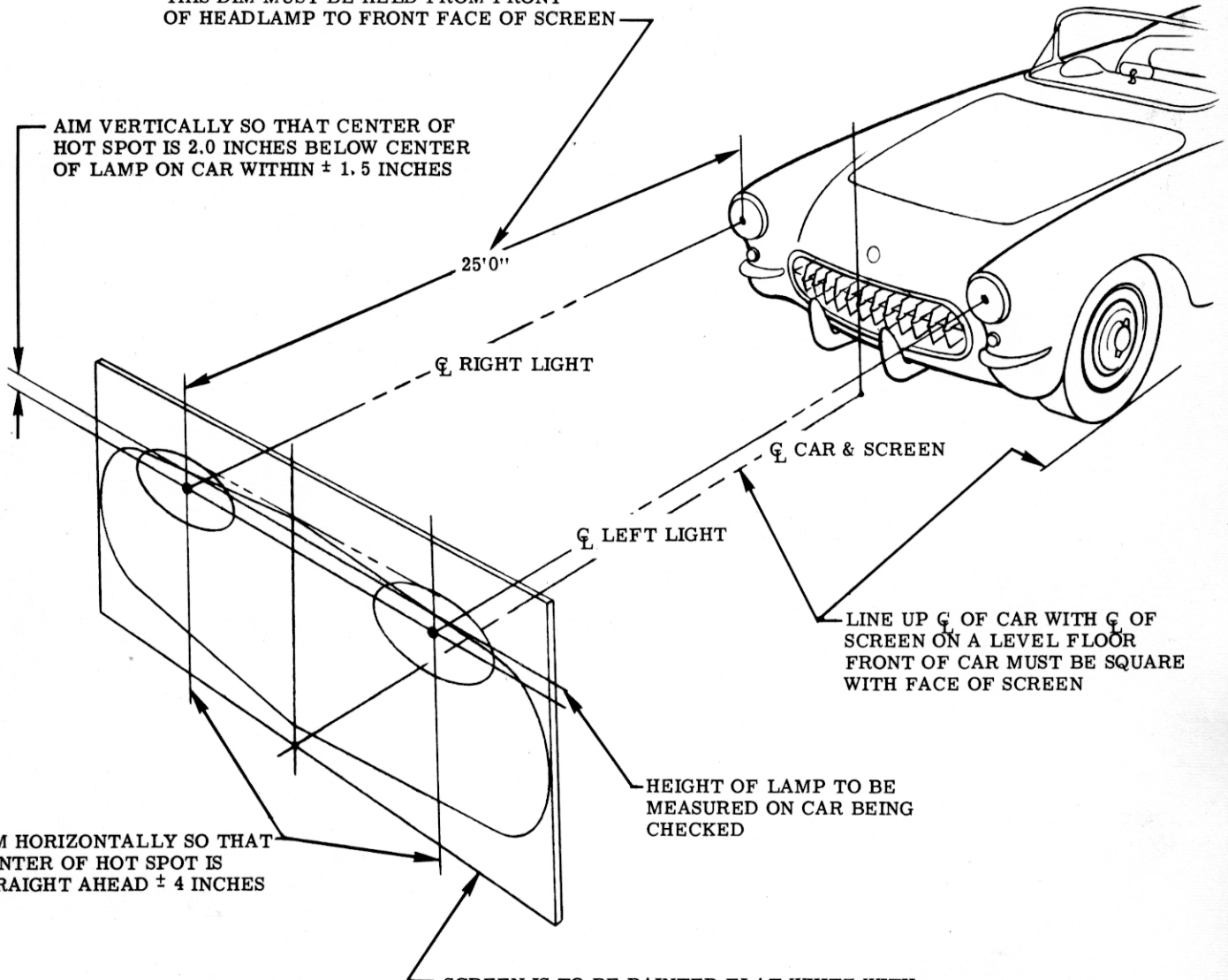

25'0"

☉ RIGHT LIGHT

☉ CAR & SCREEN

☉ LEFT LIGHT

LINE UP ☉ OF CAR WITH ☉ OF SCREEN ON A LEVEL FLOOR FRONT OF CAR MUST BE SQUARE WITH FACE OF SCREEN

HEIGHT OF LAMP TO BE MEASURED ON CAR BEING CHECKED

AIM HORIZONTALLY SO THAT CENTER OF HOT SPOT IS STRAIGHT AHEAD ± 4 INCHES

SCREEN IS TO BE PAINTED FLAT WHITE WITH BLACK LINES. SCREEN MUST BE SHIELDED FROM OUT SIDE LIGHT, ENOUGH TO ALLOW LINES TO BE CLEARLY SEEN

HEADLAMP ADJUSTING

						NAME	CORVETTE INSTRUCTION MANUAL			
						REF.	DRAWN R. L.	CHECKED L. S.	SECT.	SHEET
						DATE	PART No. 3726900		12	14.00
DATE	SYM.	REVISION RECORD		AUTH.	DR.	CK.	9-15-55			

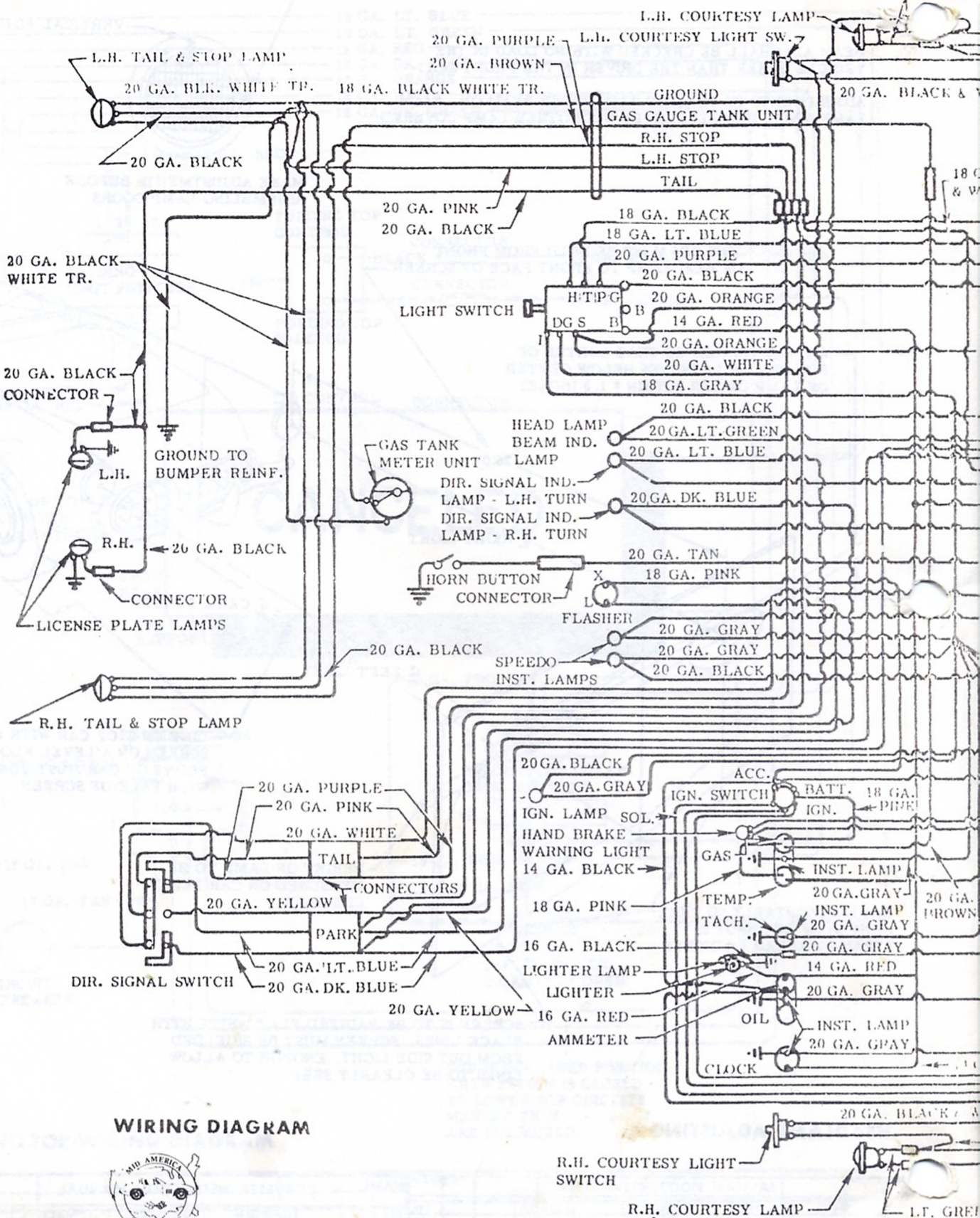

WIRING DIAGRAM



R.H. COURTESY LIGHT SWITCH

R.H. COURTESY LAMP

L.T. GREEN

GENERAL MOTORS CORPORATION

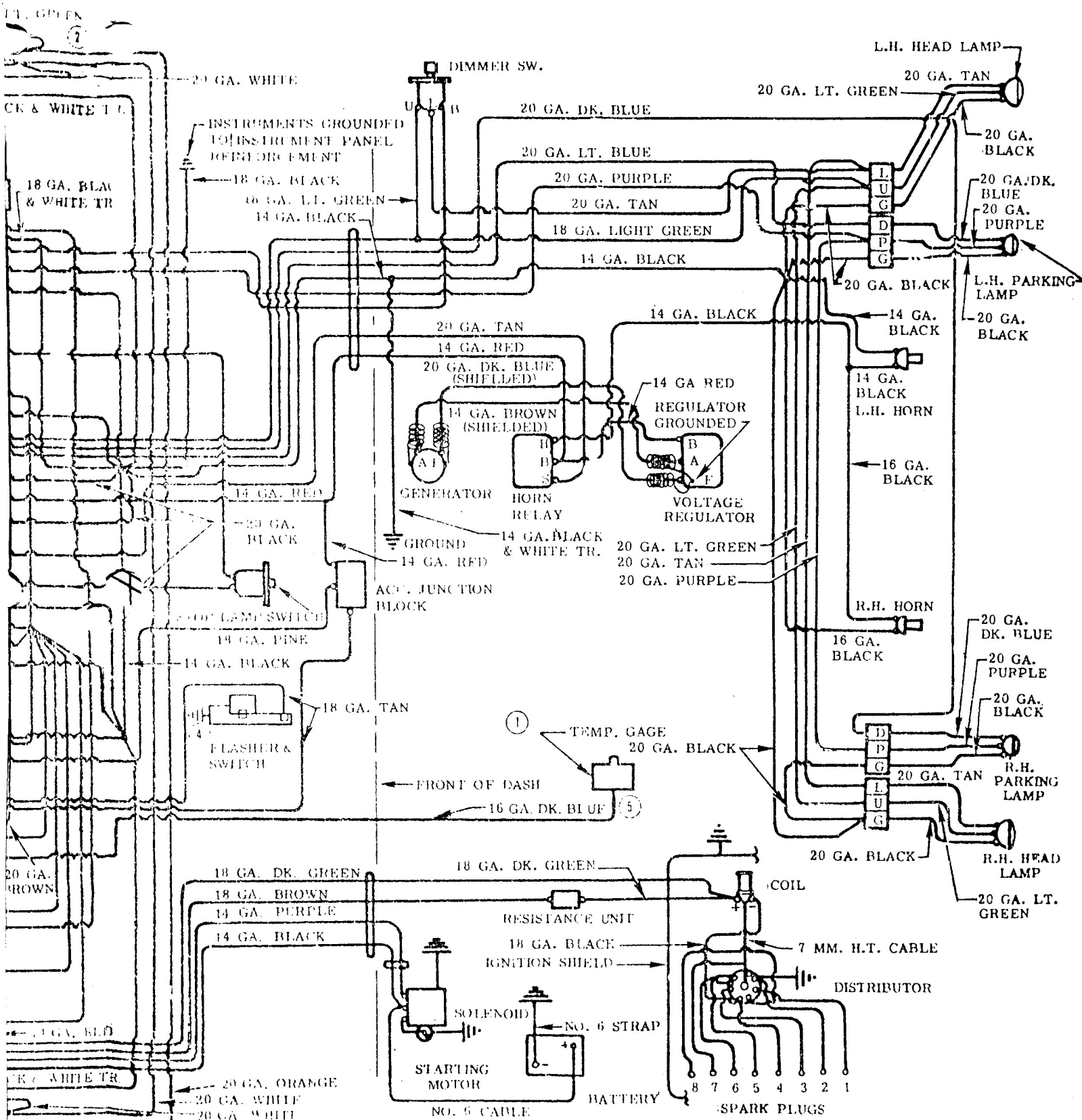

10-11-56	5	WAS 20 GA. ORANGE	4049		F	CORVETTE INSTRUCTION MANUAL				
	4	VIEW REVISED			F	REF.	DRAWN R. H.	CHECKED U.S.	SECT	SHEET
	3	COLOR ADDED								
	2	COLOR ADDED								
1-17-58	1	TEMP. GAGE ADDED	506E			DATE	PART No		12	15.00
1-28-58	078	REVISION PLACED	83HE	DR	CR	9-15-55	3726900			

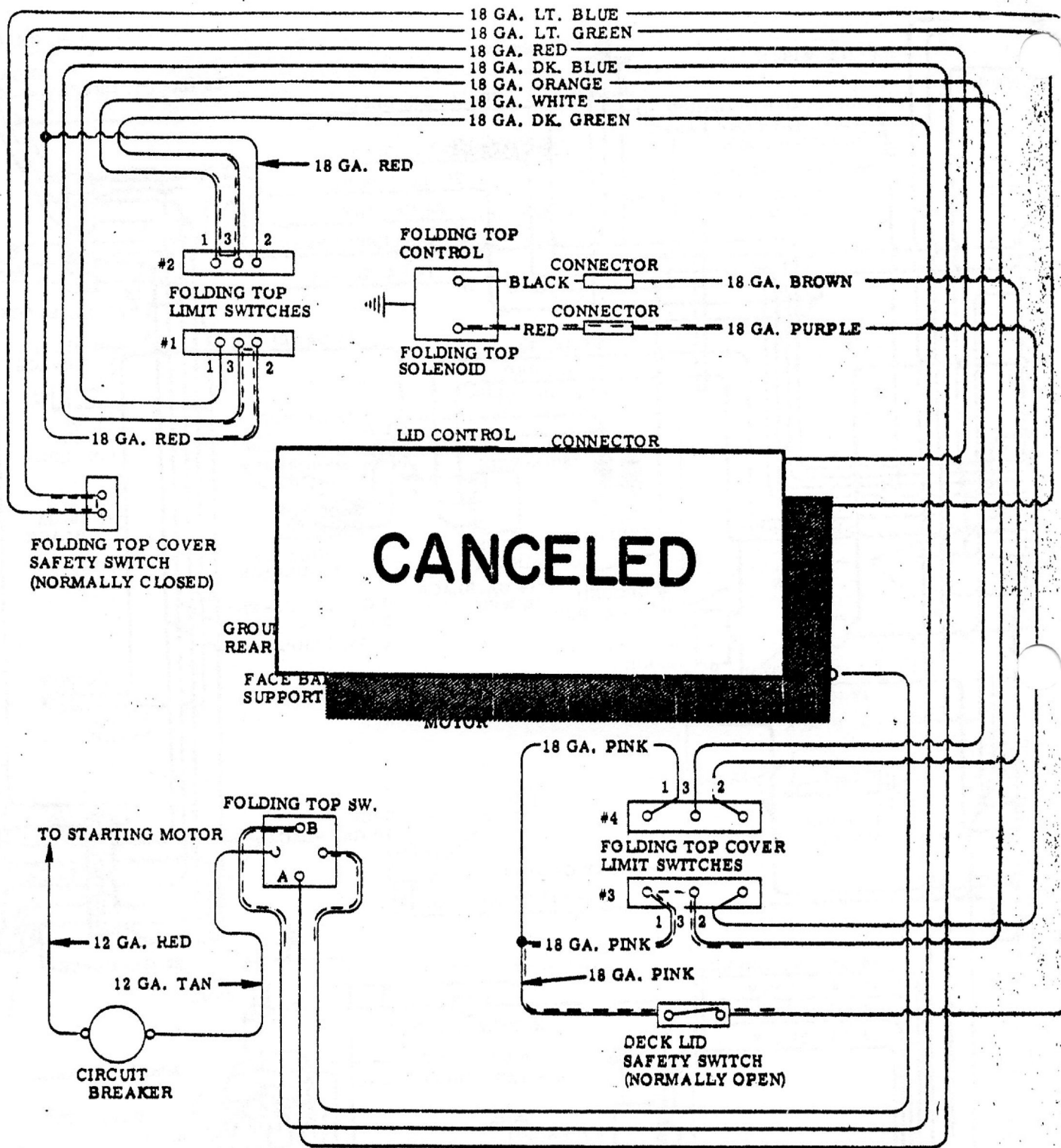

TOP IS IN HEADER POSITION WHEN SWITCH IS CLOSED. TO LOWER TOP CIRCUITS MARKED THUS - - - ARE ENERGIZED.

FOLDING TOP WIRING DIAGRAM

					NAME						
					CORVETTE INSTRUCTION MANUAL						
DATE	SYM.	REVISION	REC'D	AUTH.	DR.	CK.	REF.	DRAWN O.W.	CHECKED L.S.	SECT.	SHEET
6-9-56	1	SHEET CANCELED SEE RPO 473	9705	Y	F						
							DATE	PART No.		12	16.00
							9-15-55	3726900			

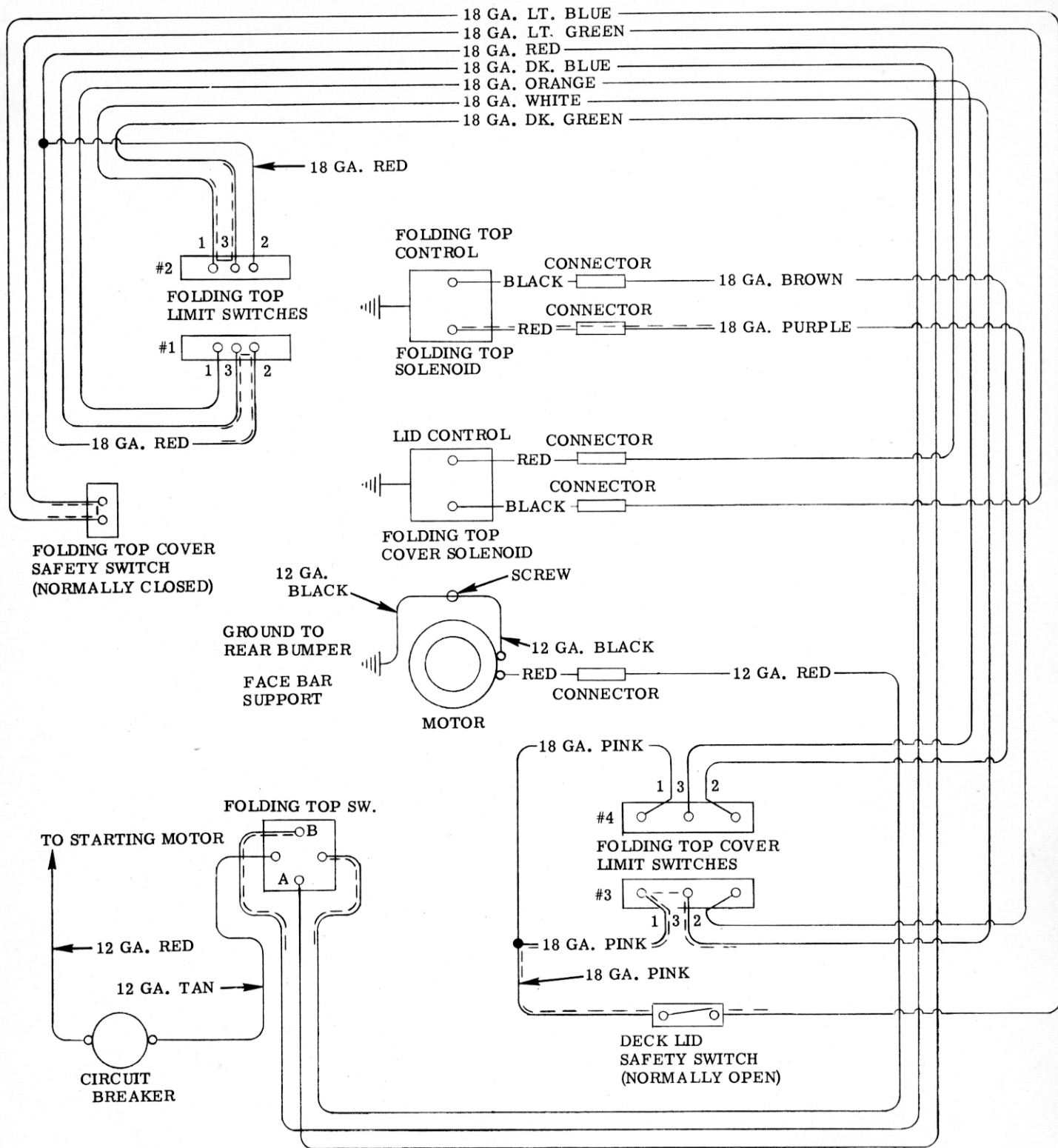

TOP IS IN HEADER POSITION WHEN SWITCH IS CLOSED. TO LOWER TOP CIRCUITS MARKED THUS - - - ARE ENERGIZED.

FOLDING TOP WIRING DIAGRAM

					NAME CORVETTE INSTRUCTION MANUAL				
					REF.	DRAWN O. W.	CHECKED L. S.	SECT.	SHEET
					DATE '9-15-55	PART No. 3726900		12	16.00
DATE	SYM.	REVISION RECORD	AUTH.	DR.	CK.				