

W.C. BROWN & SONS
LONDON

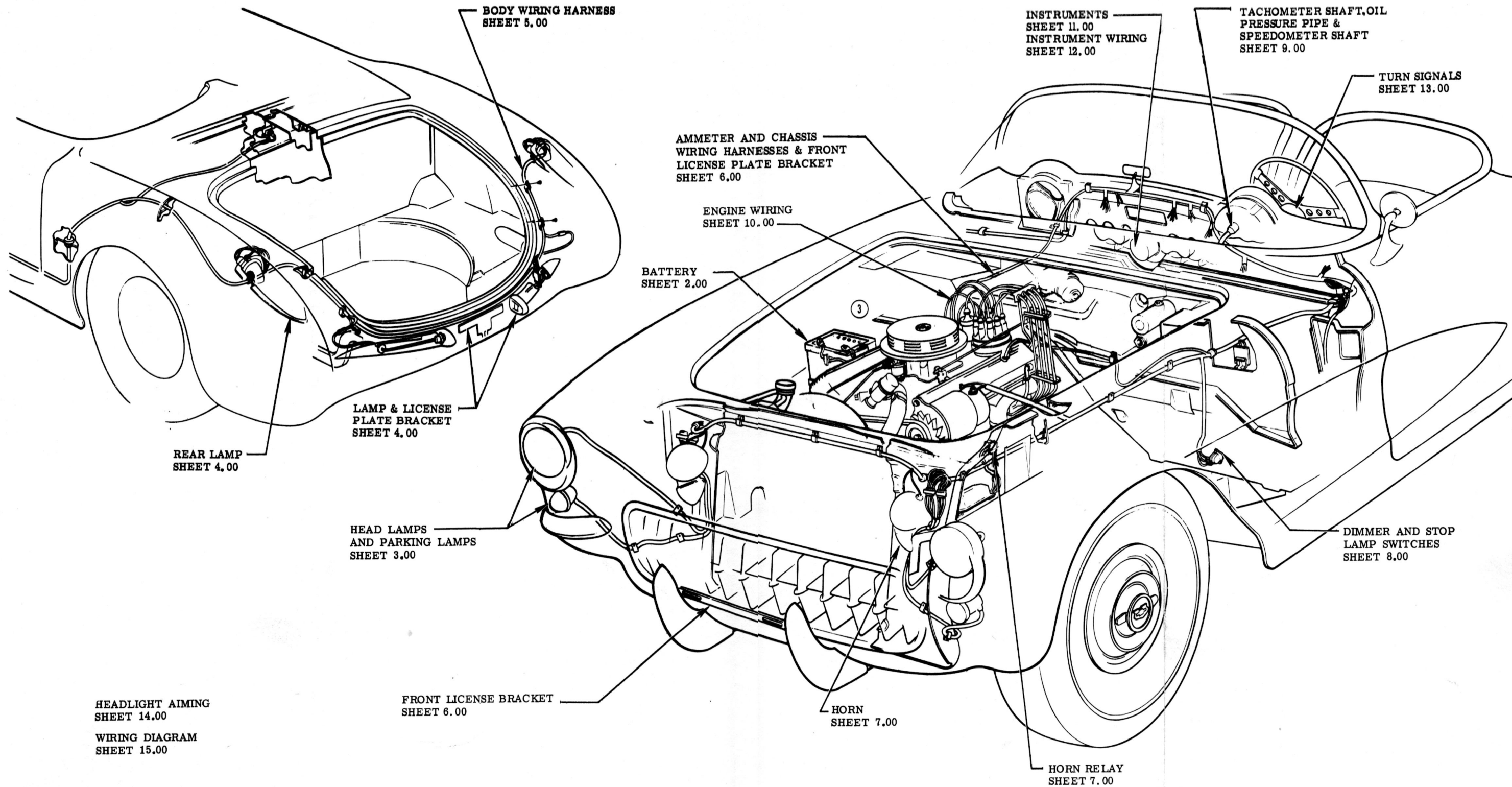



HEADLIGHT AIMING
SHEET 14.00

WIRING DIAGRAM
SHEET 15.00

ELECTRICAL

						NAME CORVETTE INSTRUCTION MANUAL				
REF.	DRAWN W.S.	CHECKED L.S.	SECT.	SHEET						
1-21-57	3	VIEW OF ENGINE REVISED		F		DATE	PART No.	12		1.00
6-4-58	2	REDRAWN & REVISED	9705	V	F	9-15-55	3726900			
DATE	SYM.	REVISION RECORD	AUTH.	DR.	CK.					

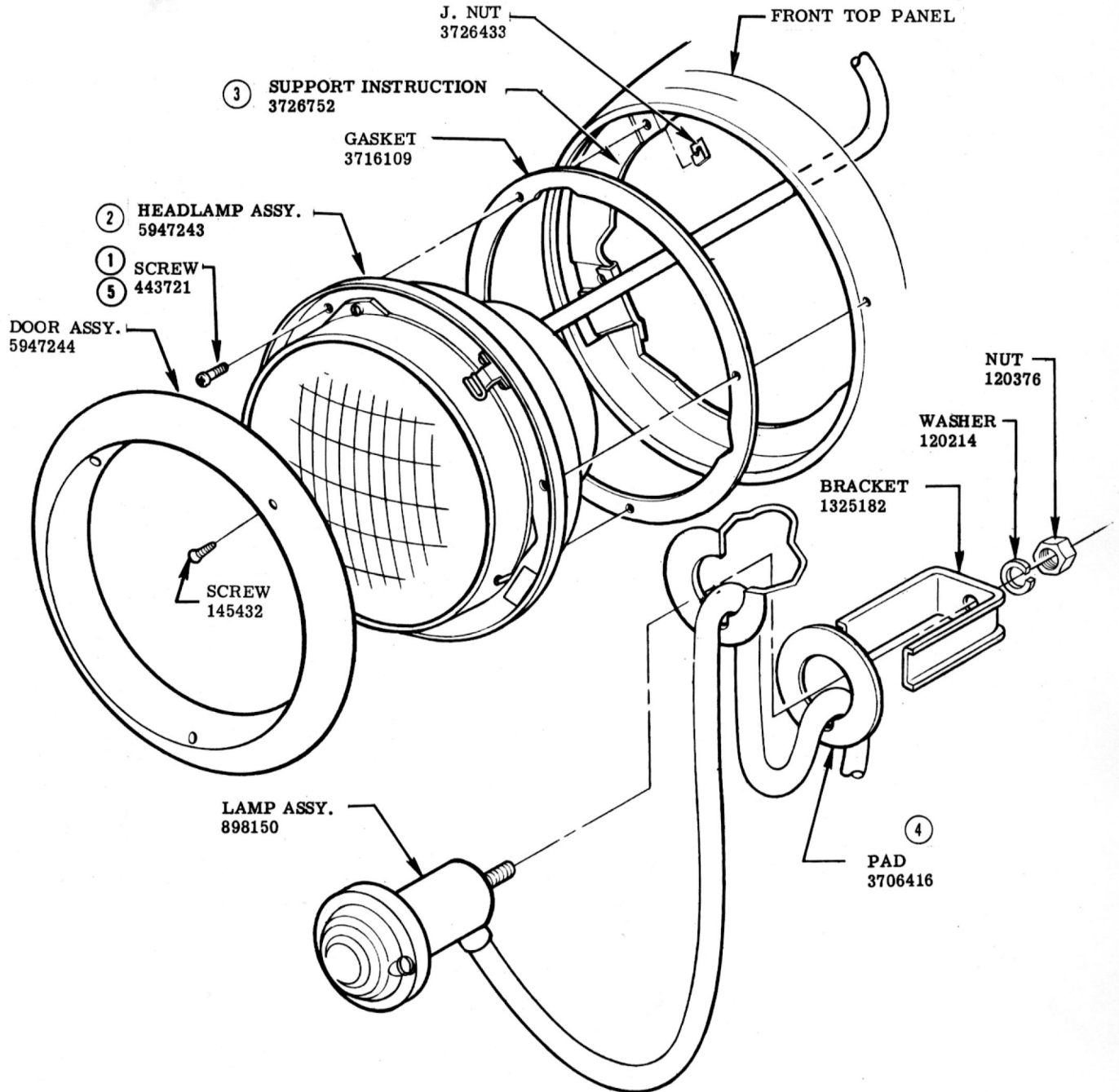

HEADLAMP & PARKING LAMP

10-11-56	5	WAS 127884	4320		F	NAME CORVETTE INSTRUCTION MANUAL				
	4	PAD RELOCATED		V	F	REF.	DRAWN J. J.	CHECKED N. D.	SECT.	SHEET
	3	PART NO. ADDED	5960			DATE 9-15-55	PART No. 3726900		12	3.00
	2	WAS 5946154								
2-2-56	1	WAS 273445								
DATE	SYM.	REVISION RECORD	AUTH.	DR.	CK.					

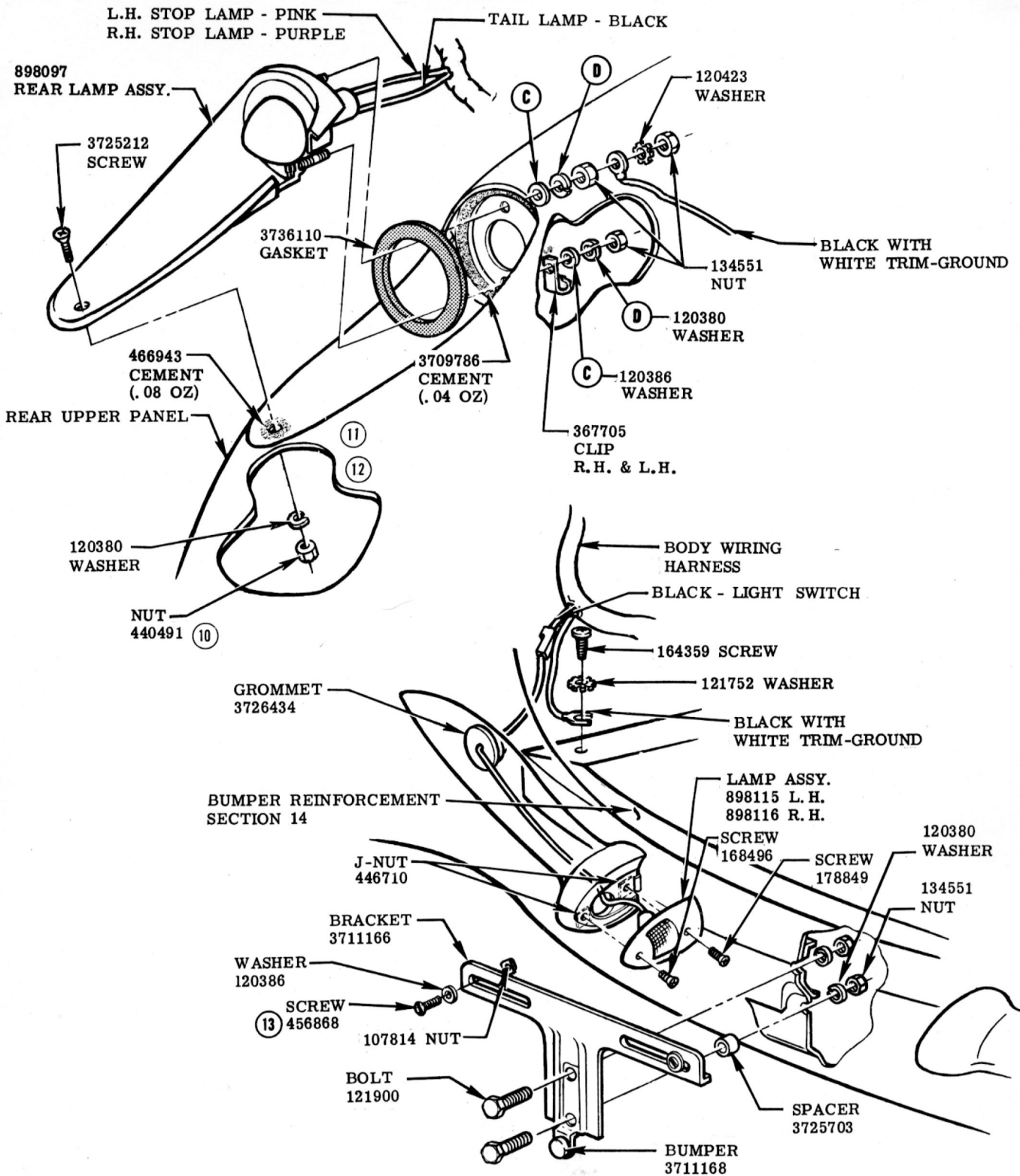

REAR LAMP, LICENSE LAMP & LICENSE PLATE BRACKET

10-11-56	13	WAS 120628	4320		F	NAME CORVETTE INSTRUCTION MANUAL				
	12	120392 WASHER REMOVED			F	REF.	DRAWN J.J.	CHECKED L.S.	SECT.	SHEET
	11	446354 WASHER REMOVED							12	4.00
	10	WAS 134551								
8-6-56	9	REDRAWN	3088			DATE 9-15-55	PART No. 3726900			
DATE	SYM.	REVISION RECORD	AUTH.	DR.	CK.					

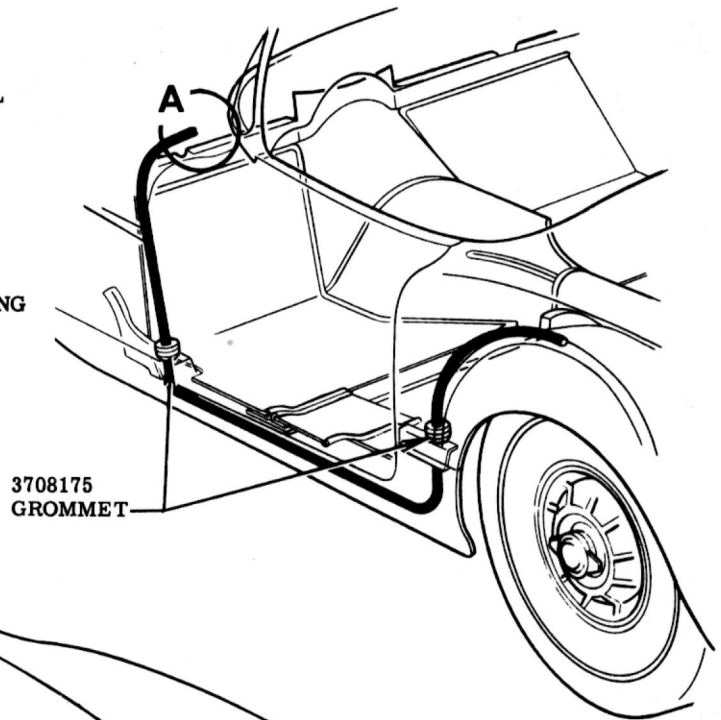
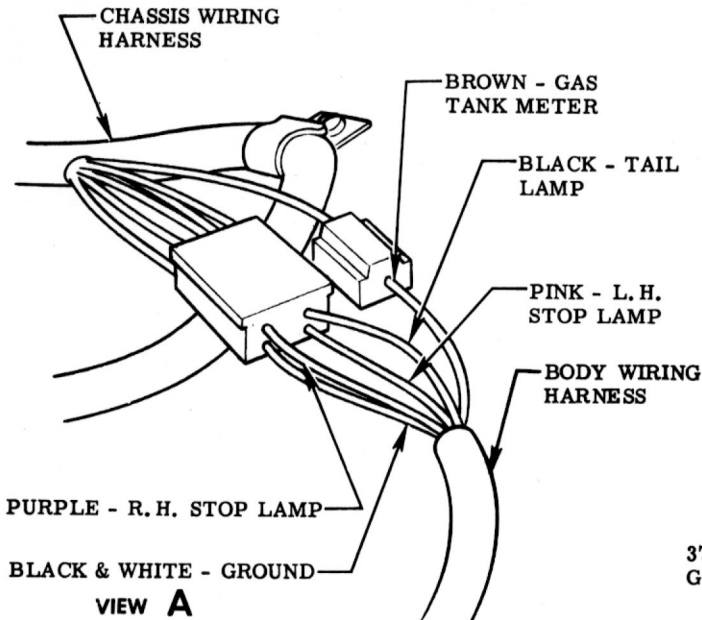

GAS TANK METER SECTION 8

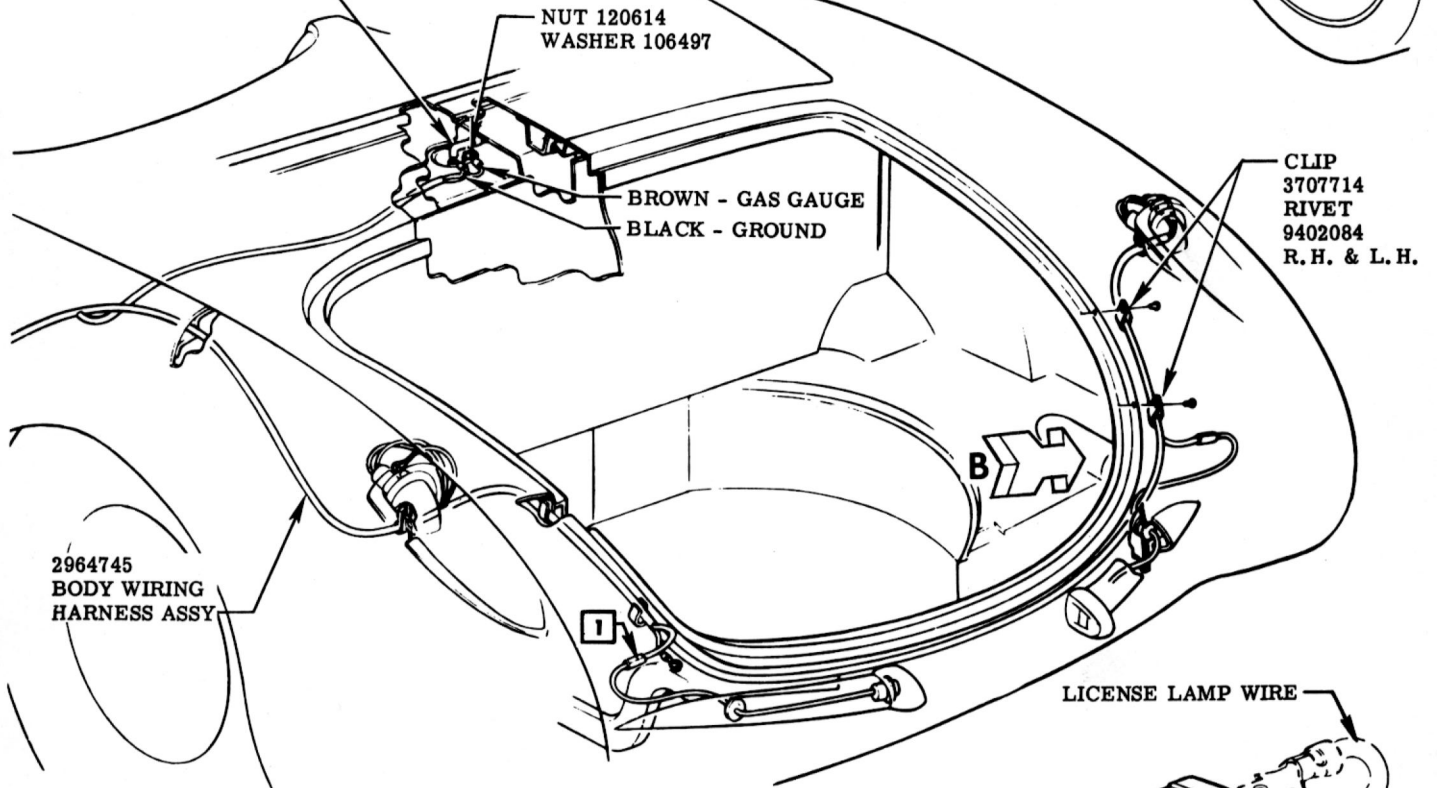

I 5297952 CONNECTOR BODY, PART OF BODY WIRING HARNESS ASSY, SHIPPED LOOSE.

PRESS INTO CONNECTOR BODY UNTIL TANG LOCKS IN PLACE
BODY WIRING HARNESS ASSY

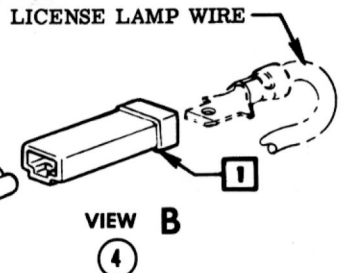

BODY WIRING HARNESS

					CORVETTE INSTRUCTION MANUAL					
DATE	SYM.	REVISION RECORD	AUTH.	DR.	CK.	REF.	DRAWN W. S.	CHECKED L. S.	SECT.	SHEET
3-25-57	4	VIEW ADDED	7938	V	F					
6-4-56	3	REDRAWN & REVISED	9705	V	F				12	5.00
						DATE	PART No.			
						9-15-55	3726900			

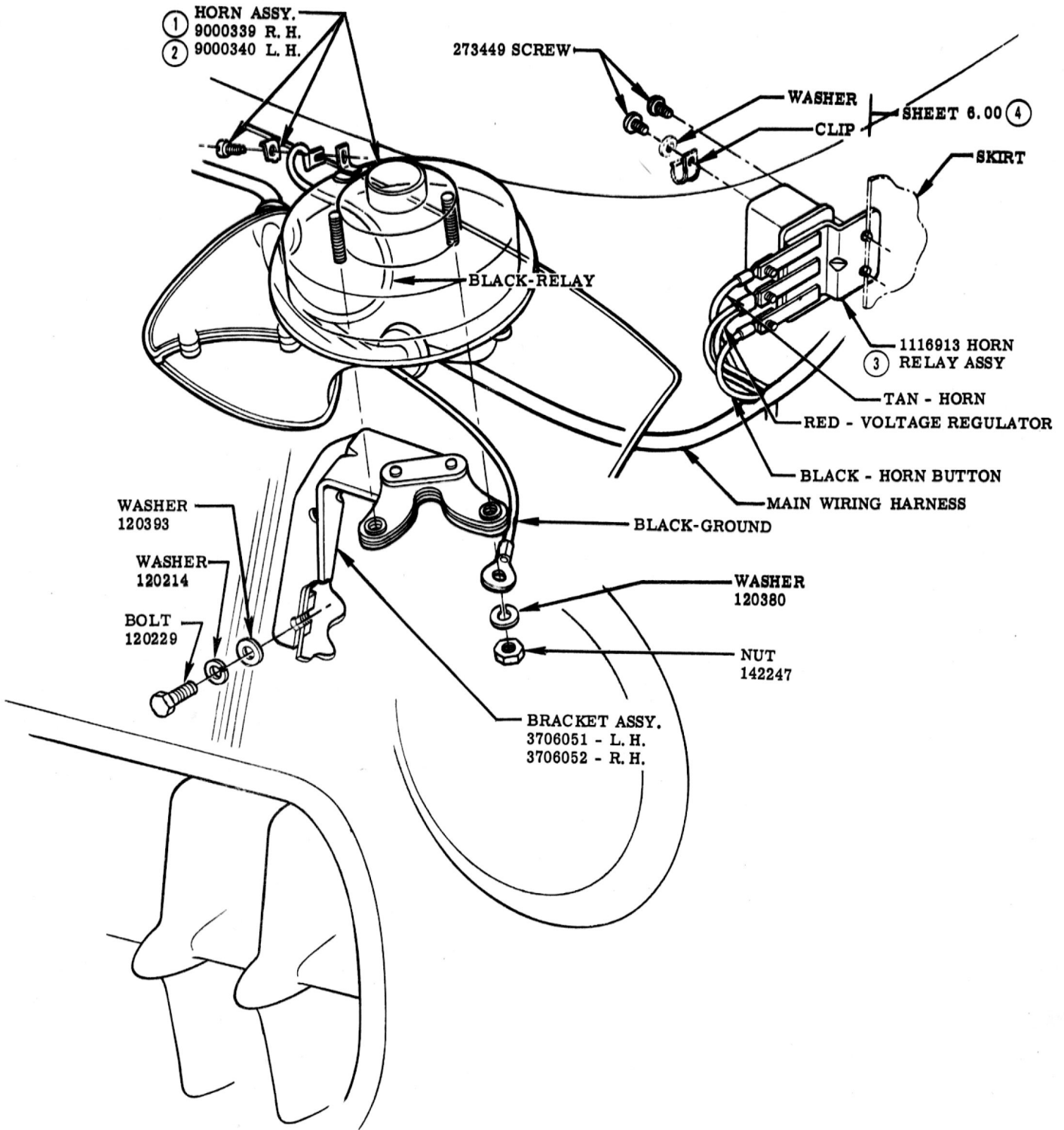

HORN & HORN RELAY

REVISION RECORD						CORVETTE INSTRUCTION MANUAL				
DATE	SYM.	REVISION RECORD	AUTH.	DR.	CK.	NAME	DRAWN	CHECKED	SECT.	SHEET
1-21-57	4	NOTE ADDED			F	REF.	J. J.	N. D.	12	7.00
	3	RELAY ROTATED 90°	6145	V						
	2	WAS 1999760			F	DATE	PART No.			
10-22-56	1	WAS 1999759	5032			9-15-55	3726900			

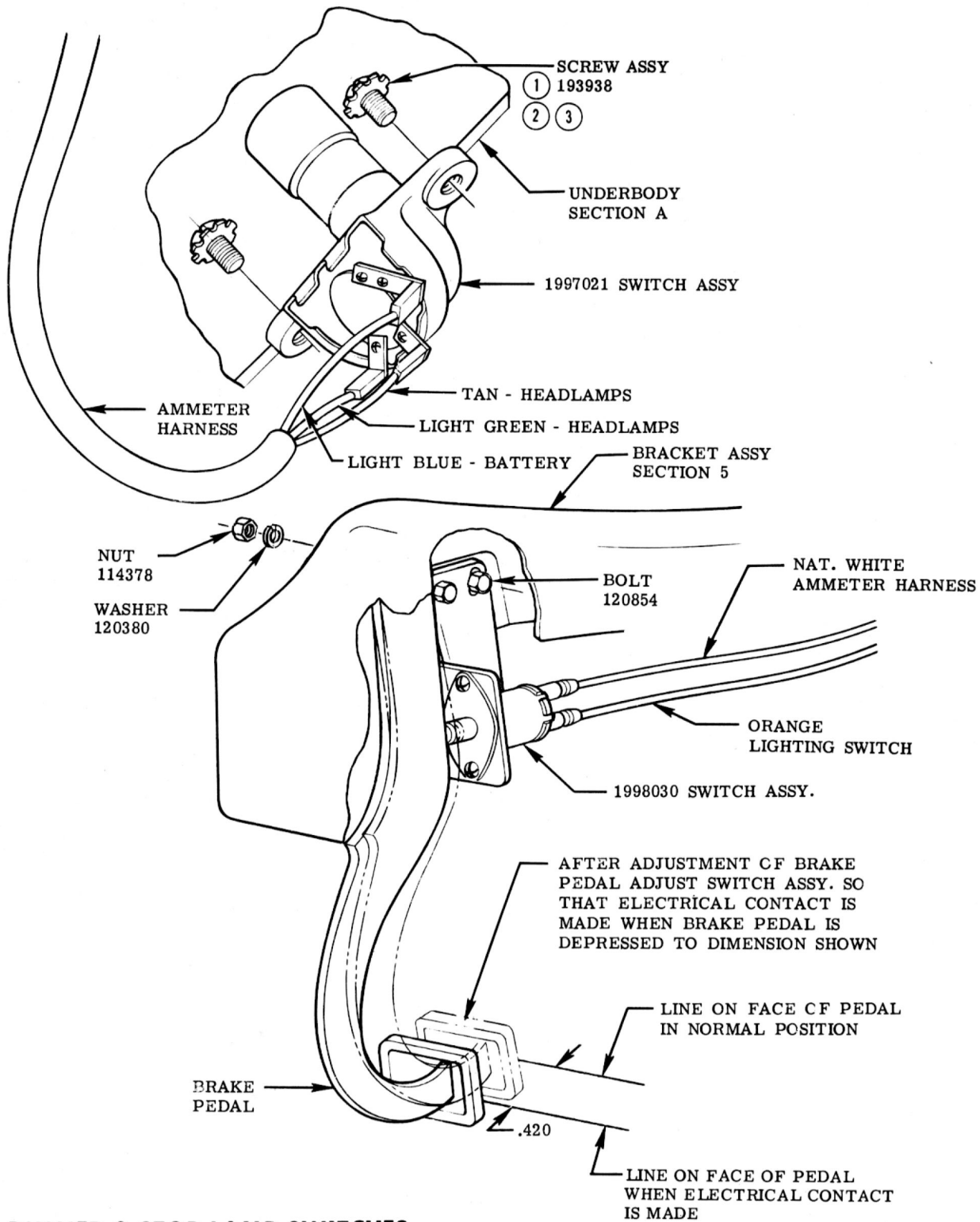

DIMMER & STOP LAMP SWITCHES

REVISION RECORD						CORVETTE INSTRUCTION MANUAL				
DATE	SYM.	REVISION	AUTH.	DR.	CK.	REF.	DRAWN	CHECKED	SECT.	SHEET
11-5-56	3	106972 BOLT WITH 103319 LW OPTION REMOVED	5290		F		J. J.	L. S.	12	8.00
7-16-56	2	106972-103319 OPT. ADDED	9578	V	F					
3-6-56	1	WAS 455489	8284		F					
						DATE	PART No.			
						9-15-55	3726900			

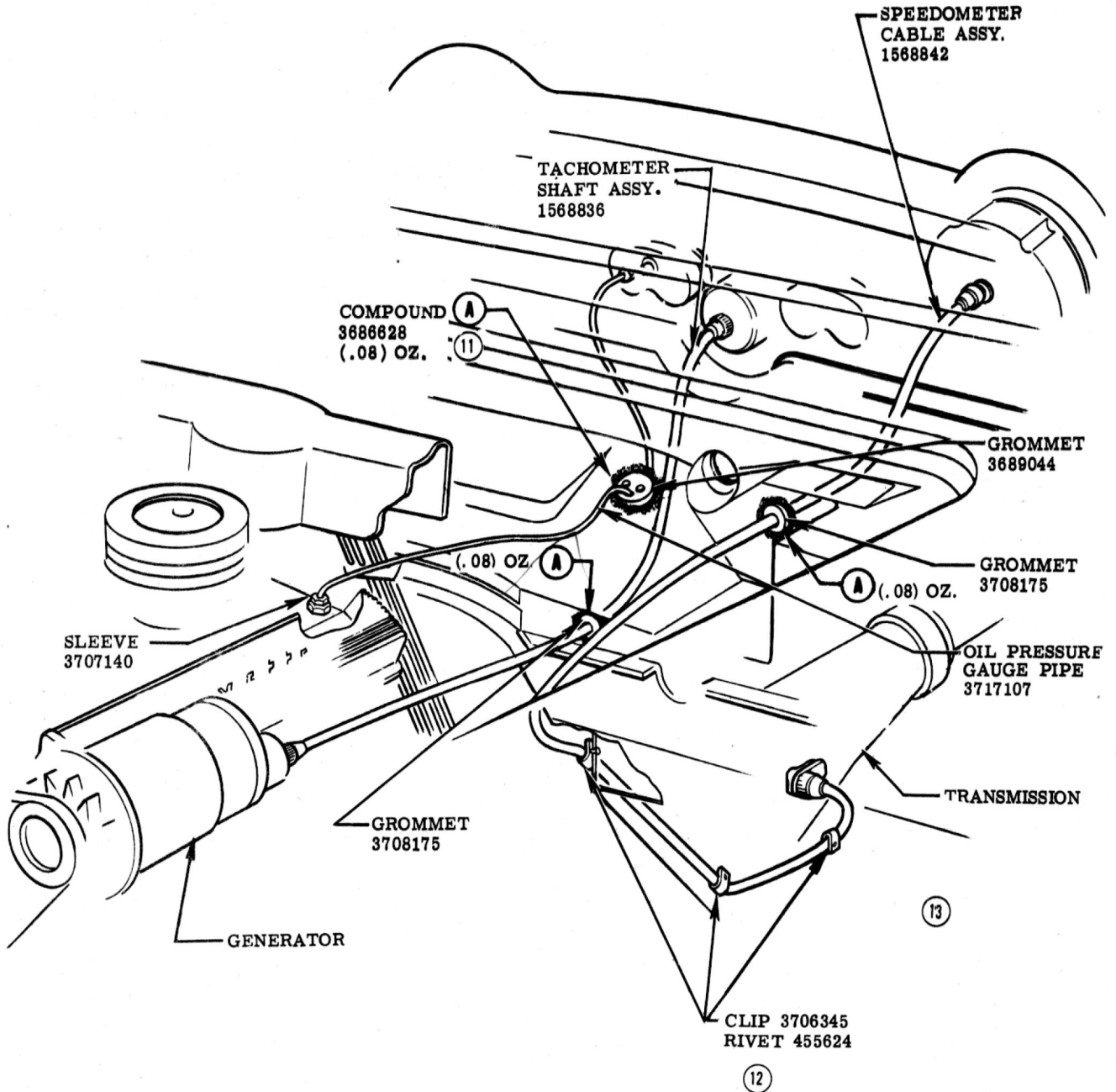

TACHOMETER SHAFT, OIL PRESSURE PIPE & SPEEDOMETER SHAFT

					NAME CORVETTE INSTRUCTION MANUAL				
	13	NOTE REMOVED			REF.	DRAWN J.J.	CHECKED L.S.	SECT.	SHEET
1-21-57	12	NOTE REMOVED						12	9.00
	11	PART ADDED			DATE	PART No.			
11-13-56	10	REDRAWN	4059	V	9-15-55	3726900			
DATE	SYM.	REVISION RECORD	AUTH.	DR.	CK.				

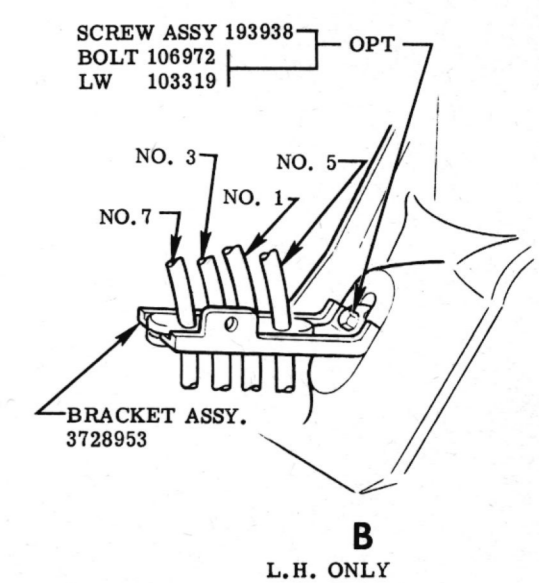
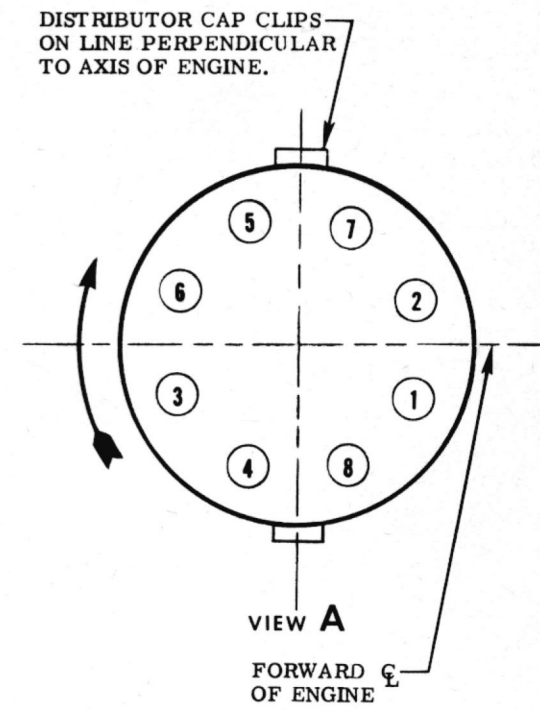
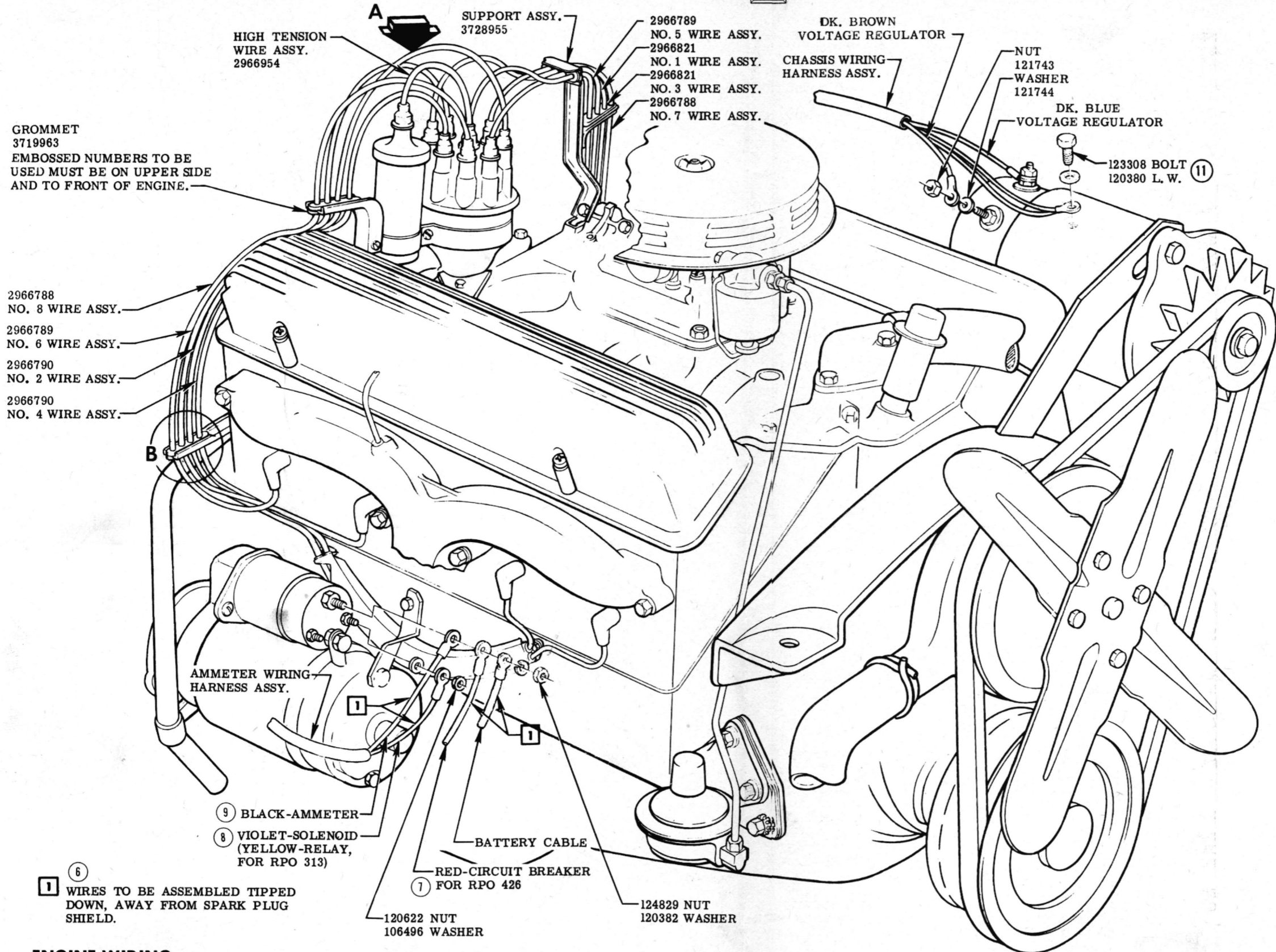

ENGINE WIRING

						CORVETTE INSTRUCTION MANUAL				
						REF.	DRAWN W.S.	CHECKED L.S.	SECT.	SHEET
		11	PARTS ADDED		F				12	10.00
4-22-57		10	REDRAWN	7717	V	DATE	PART No.	3726900		
			REVISION RECORD		CK.	9-15-55				

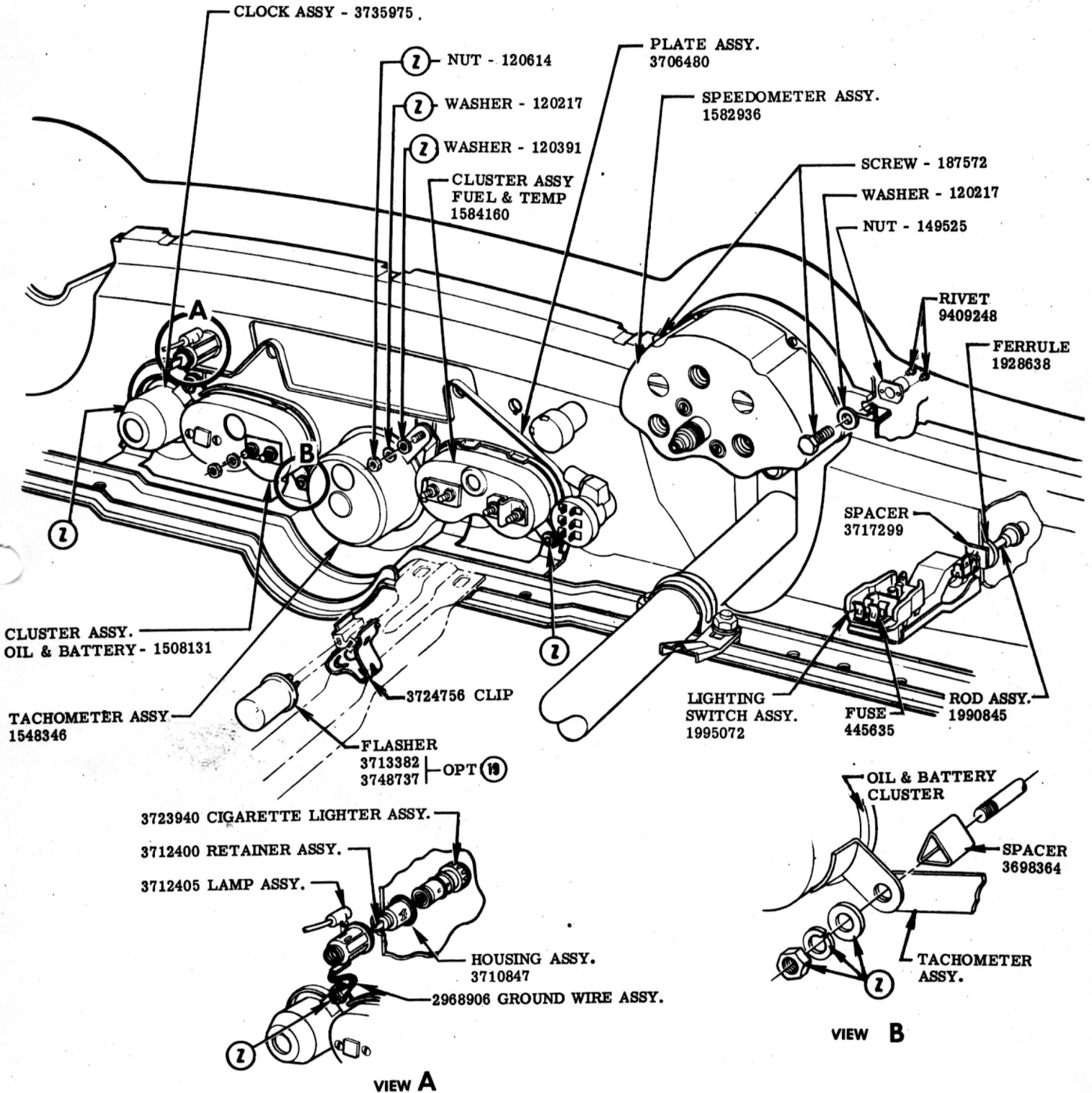

INSTRUMENTS

					CORVETTE INSTRUCTION MANUAL				
					NAME	DRAWN O.W.	CHECKED L.S.	SECT.	SHEET
	19	WAS 3713382-3715248 OPT.		F	REF.			12	11.00
4-9-57	18	REDRAWN	8881	V	DATE	PART No.	3726900		
DATE	SYM.	REVISION RECORD	AUTH.	DR. CK.	9-15-55				

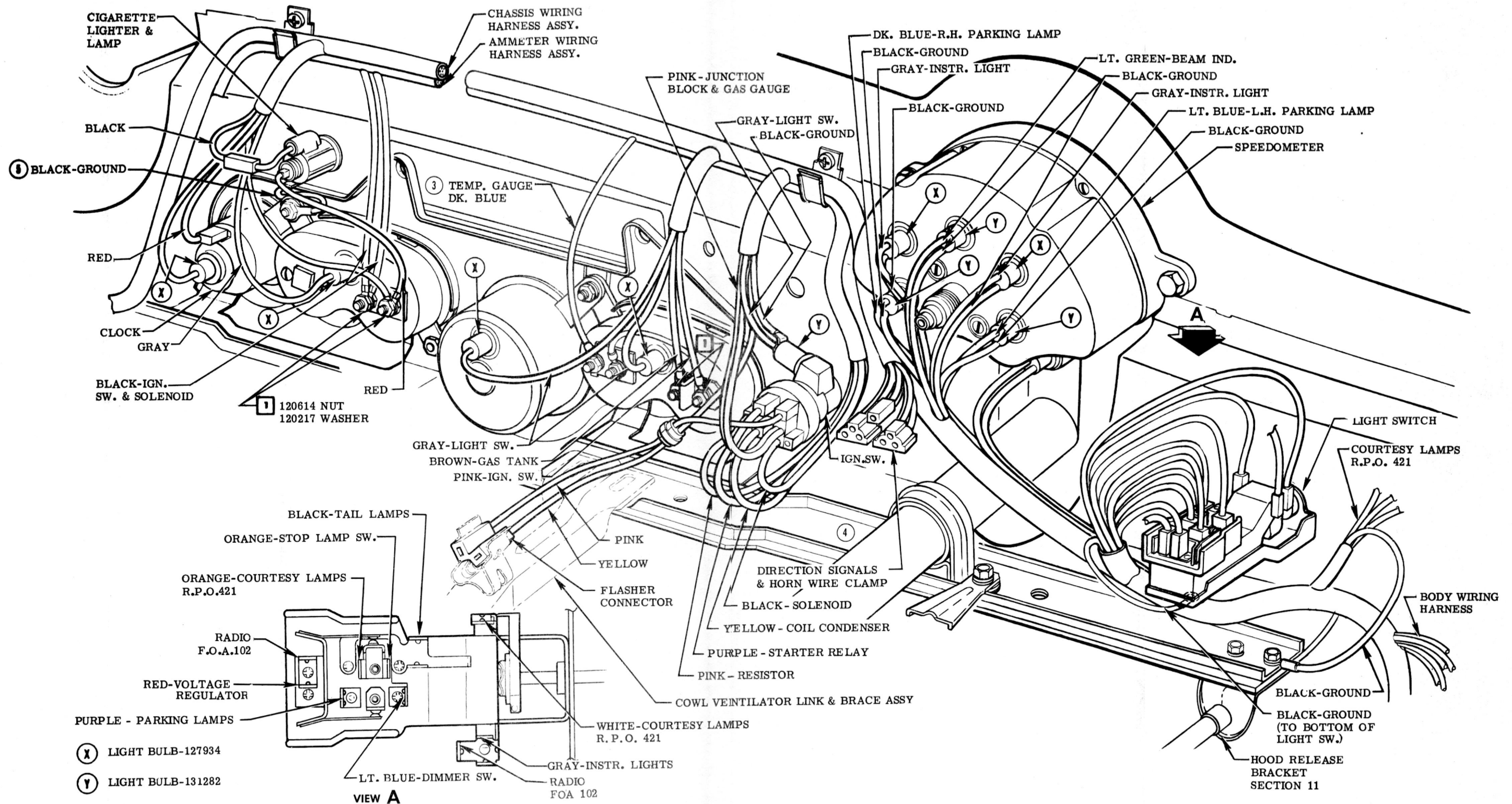

INSTRUMENT WIRING

NAME							CORVETTE INSTRUCTION MANUAL			
1-28-57	5	WAS PART OF HARNESS ASSY.	5902	V	F	REF.	DRAWN	CHECKED	SECT.	SHEET
12-18-56	4	FLASHER CONN. RELOCATED	185	V	F		J. J.	L. S.		
10-11-56	3	WAS COLOR-ORANGE	4049	V	F	DATE	PART No.		12	12.00
6-4-56	2	REDRAWN & REVISED	9705	V	F	9-15-55	3726900			
DATE	SYM.	REVISION RECORD	AUTH.	DR.	CK.					

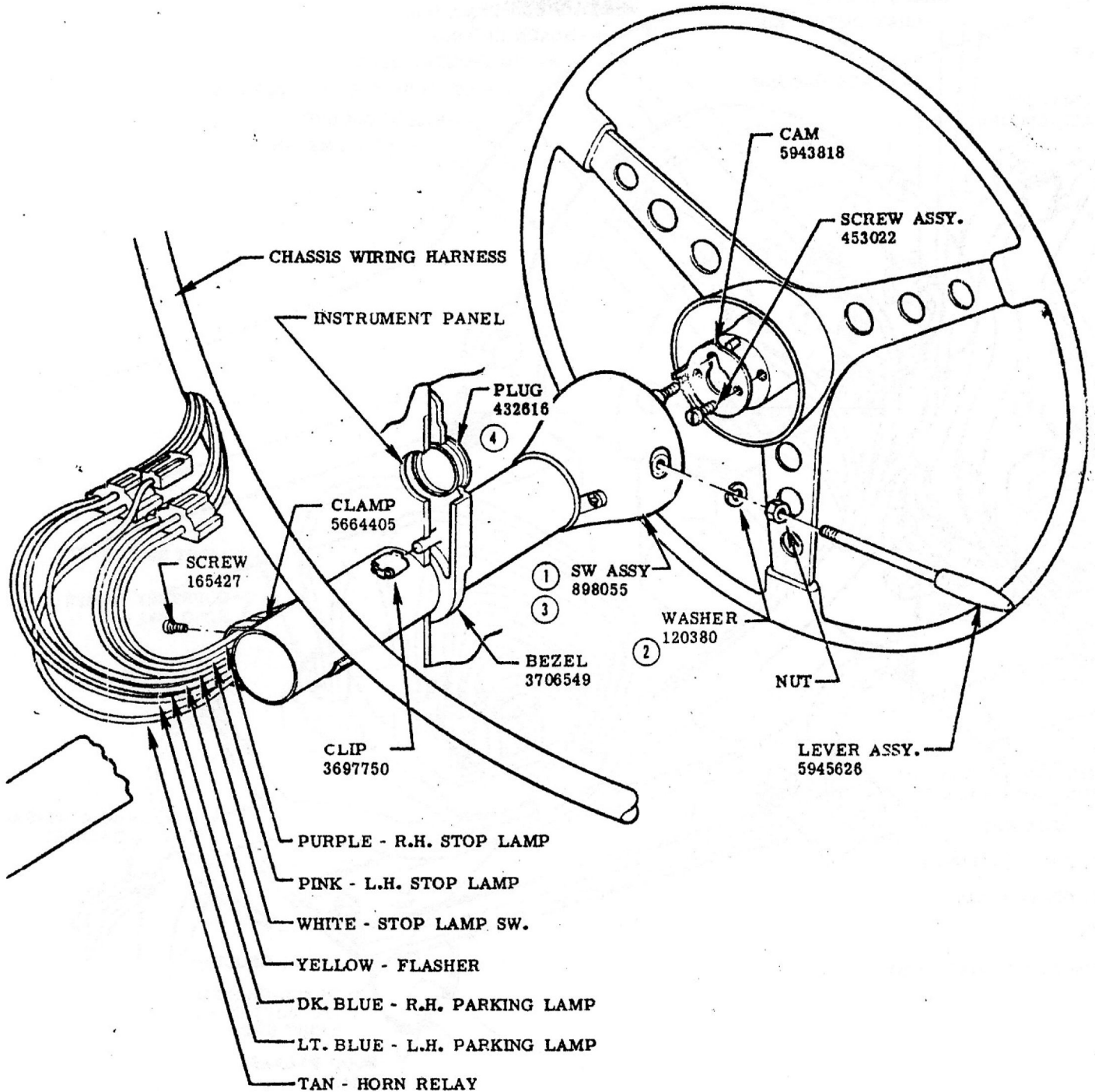

DIRECTIONAL SIGNALS & HORN WIRE CLAMP

						CORVETTE INSTRUCTION MANUAL				
3-12-56	4	NO. ADDED	8148		F	REF.	DRAWN O.W.	CHECKED L.S.	SECT.	SHEET
2-27-56	3	WAS 898056	6764		F				12	13.00
	2	NO. ADDED	—		F					
1-16-56	1	WAS 897763	5287			DATE	PART No.			
DATE	SYM.	REVISION RECORD	AUTH.	DR.	CK.	9-15-55	3726900			

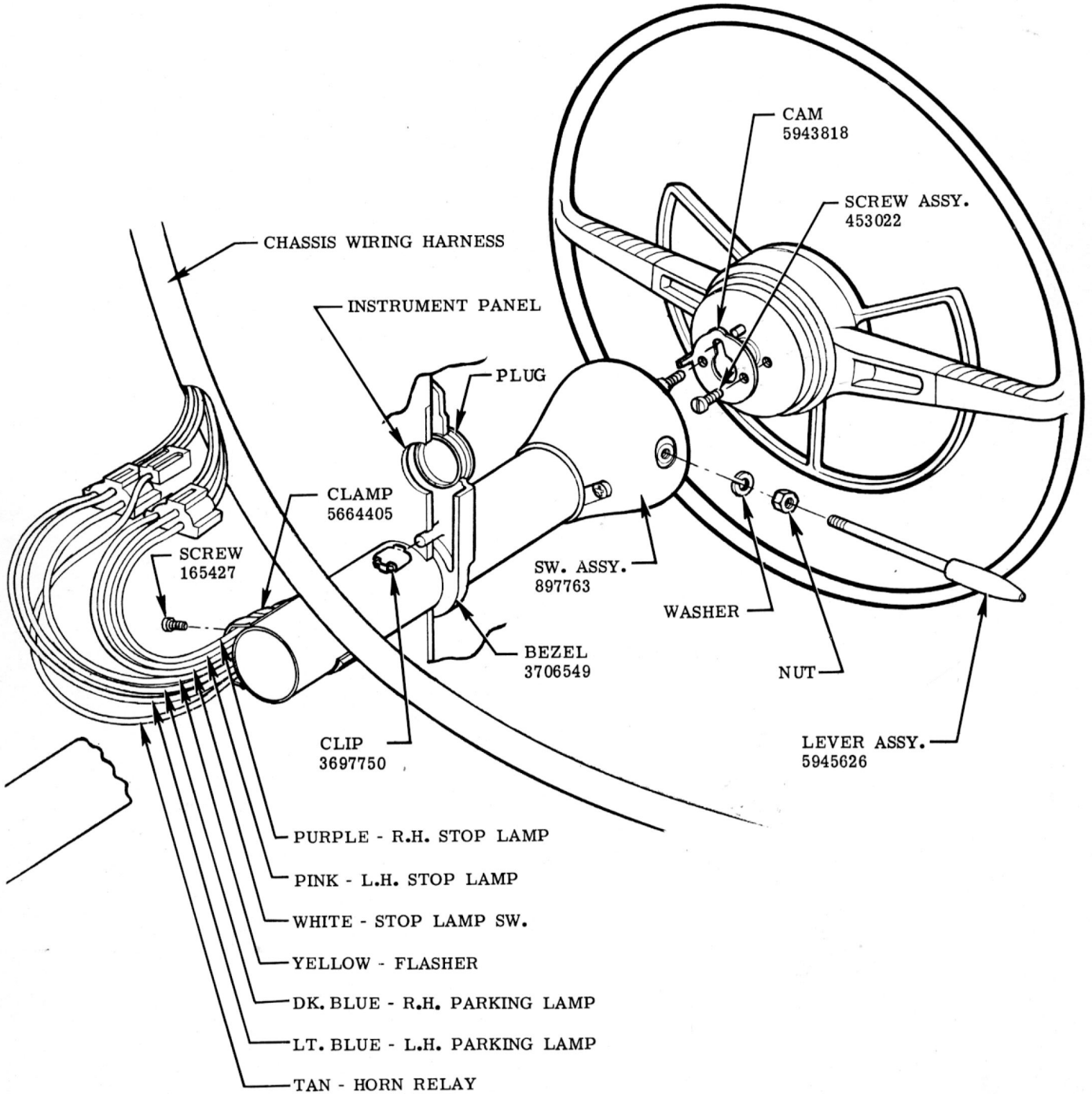

DIRECTIONAL SIGNALS & HORN WIRE CLAMP

						NAME CORVETTE INSTRUCTION MANUAL				
						REF.	DRAWN O. W.	CHECKED L. S.	SECT.	SHEET
						DATE 9-15-55	PART No. 3726900		12	13.00
DATE	SYM.	REVISION RECORD		AUTH.	DR.	CK.				



BEAM AIM SHALL BE CHECKED WITH NO LOAD IN THE VEHICLE OTHER THAN THE DRIVER IN THE FRONT SEAT

ADJUSTMENTS TO BE MADE WITH UPPER BEAM ON. EACH LAMP AIMED INDEPENDENTLY WITH OTHER LAMP COVERED

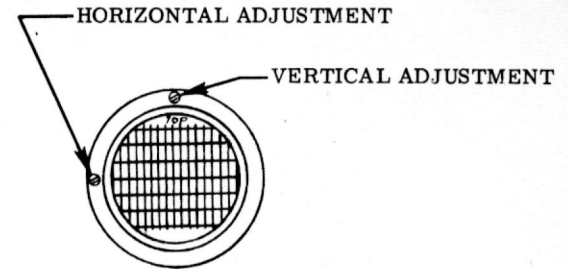

MAKE ADJUSTMENTS BEFORE ASSEMBLING LAMP DOORS

THIS DIM MUST BE HELD FROM FRONT OF HEADLAMP TO FRONT FACE OF SCREEN

AIM VERTICALLY SO THAT CENTER OF HOT SPOT IS 2.0 INCHES BELOW CENTER OF LAMP ON CAR WITHIN ± 1.5 INCHES

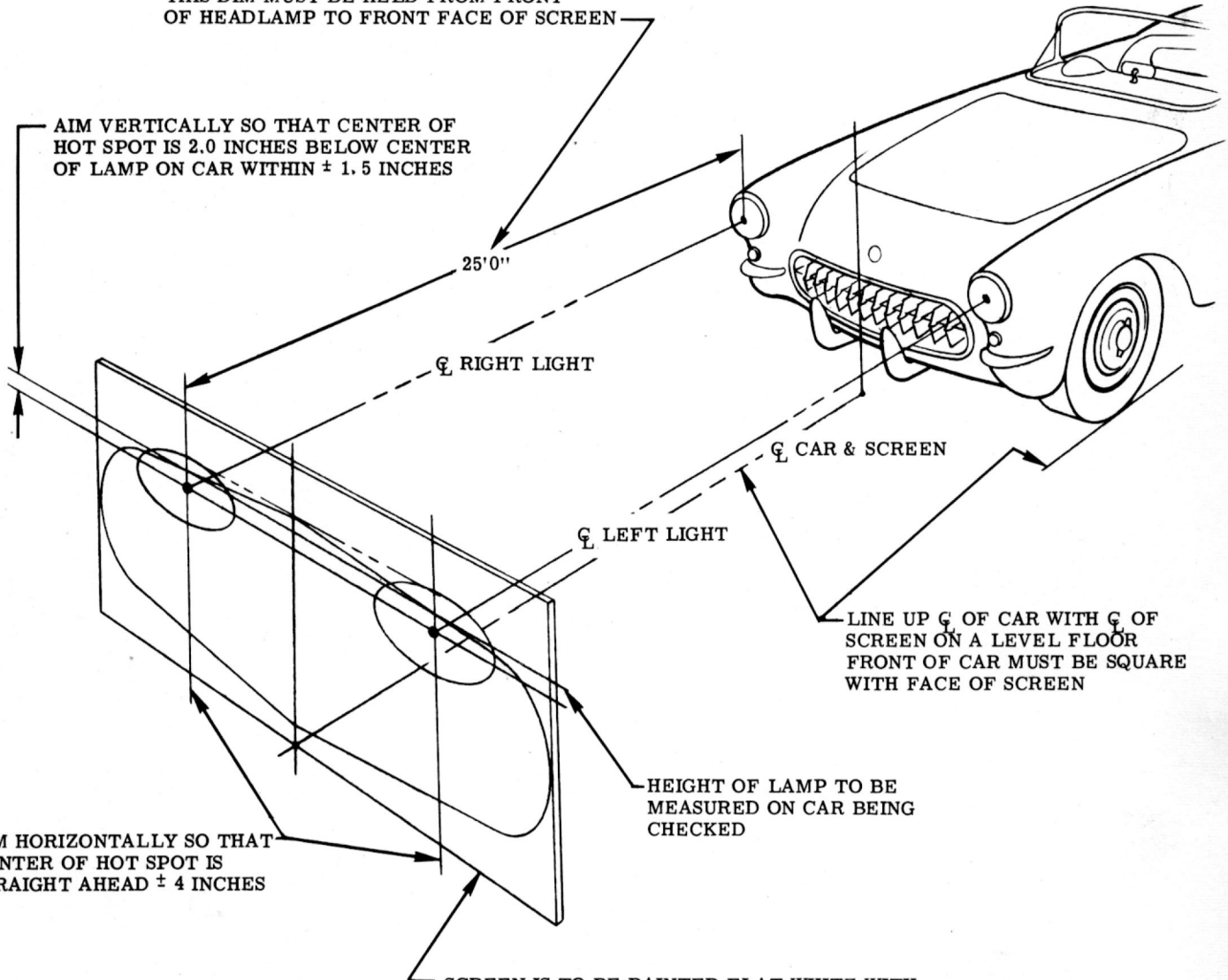

AIM HORIZONTALLY SO THAT CENTER OF HOT SPOT IS STRAIGHT AHEAD ± 4 INCHES

SCREEN IS TO BE PAINTED FLAT WHITE WITH BLACK LINES. SCREEN MUST BE SHIELDED FROM OUT SIDE LIGHT, ENOUGH TO ALLOW LINES TO BE CLEARLY SEEN

HEADLAMP ADJUSTING

					NAME CORVETTE INSTRUCTION MANUAL				
					REF.	DRAWN R. L.	CHECKED L. S.	SECT.	SHEET
					DATE	PART No. 3726900		12	14.00
DATE	SYM.	REVISION RECORD	AUTH.	DR.	CK.	9-15-55			

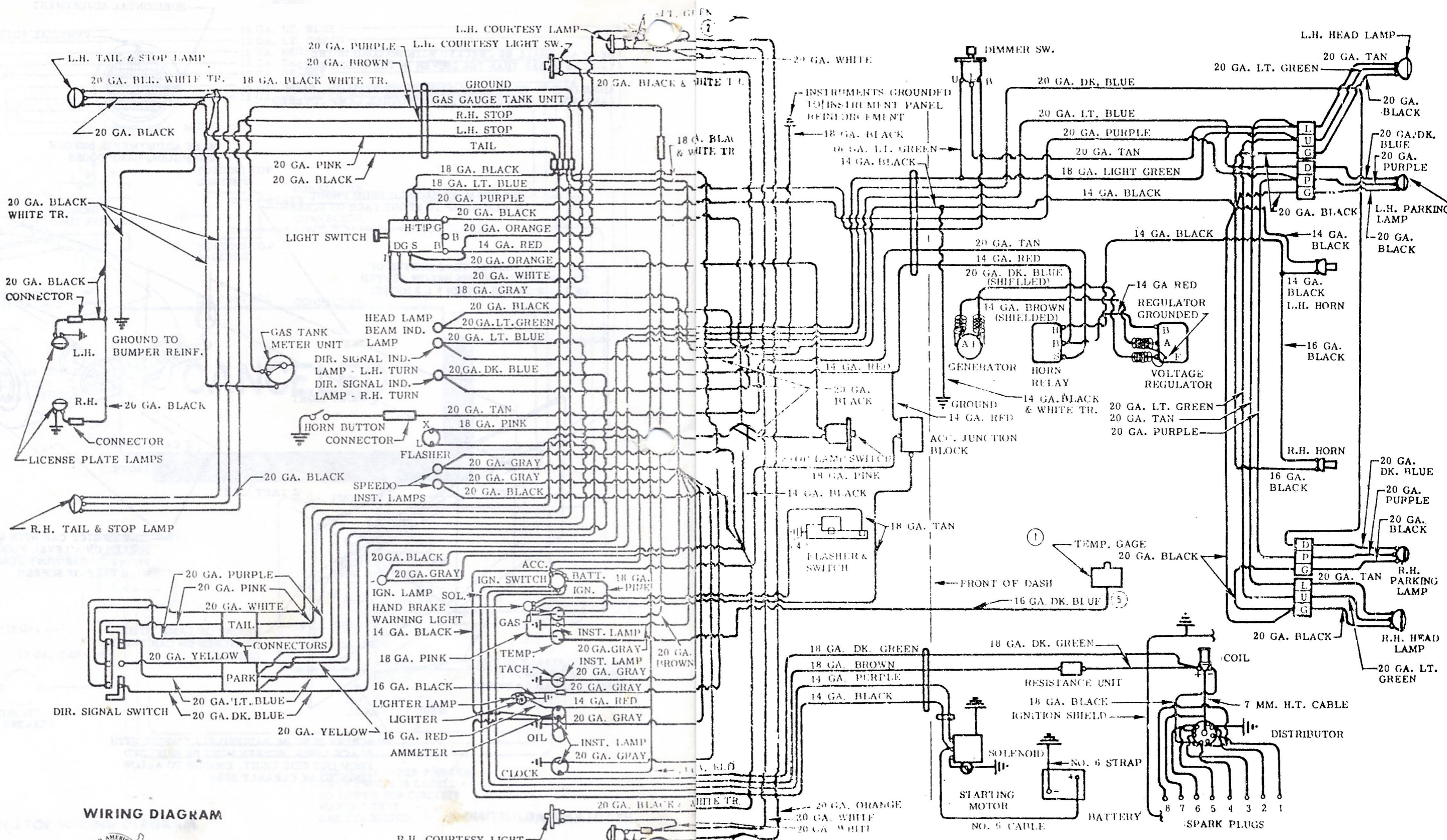

WIRING DIAGRAM



REV.		DESCRIPTION	DATE	BY	CHK.	NAME	CORVETTE INSTRUCTION MANUAL				
5		WAS 20 GA. ORANGE	4-24-55				REF.	DRAWN R.H.	CHECKED I.S.	SFT	2HET
4		VIEW REVISED									
3		COLOR ADDED									
2		COLOR ADDED									
1		TEMP. GAGE ADDED	9-15-55				DATE	PART No		12	15.00
		REVISION PLACED						3726900			

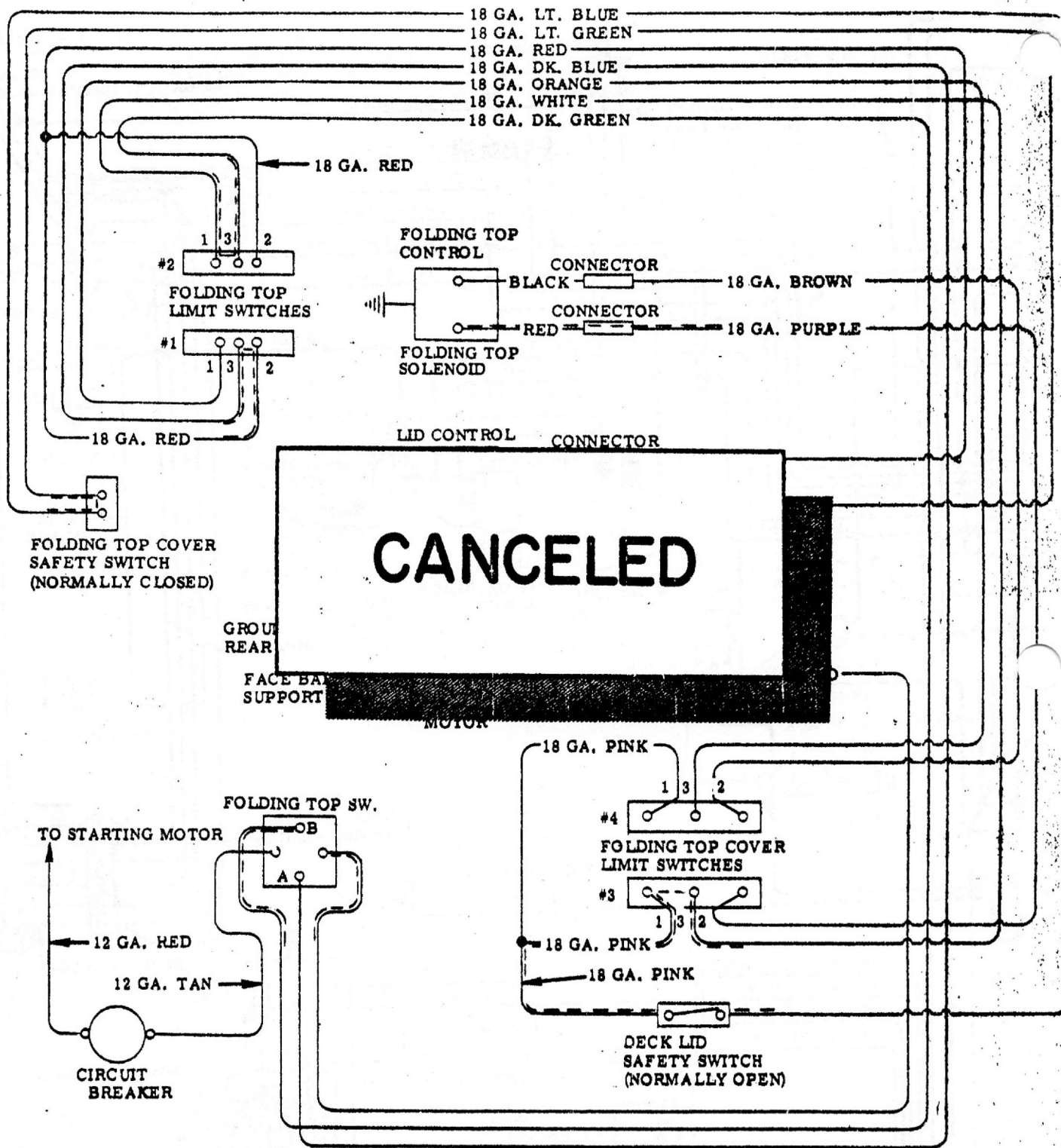

TOP IS IN HEADER POSITION WHEN SWITCH IS CLOSED. TO LOWER TOP CIRCUITS MARKED THUS - - - ARE ENERGIZED.

FOLDING TOP WIRING DIAGRAM

					NAME				
					CORVETTE INSTRUCTION MANUAL				
DATE	SYM.	REVISION	AUTH.	DR. CK.	REF.	DRAWN O.W.	CHECKED L.S.	SECT.	SHEET
6-9-56	1	SHEET CANCELED SEE RPO 473	9705	Y F					
					DATE	PART No.		12	16.00
					'9-15-55	3726900			

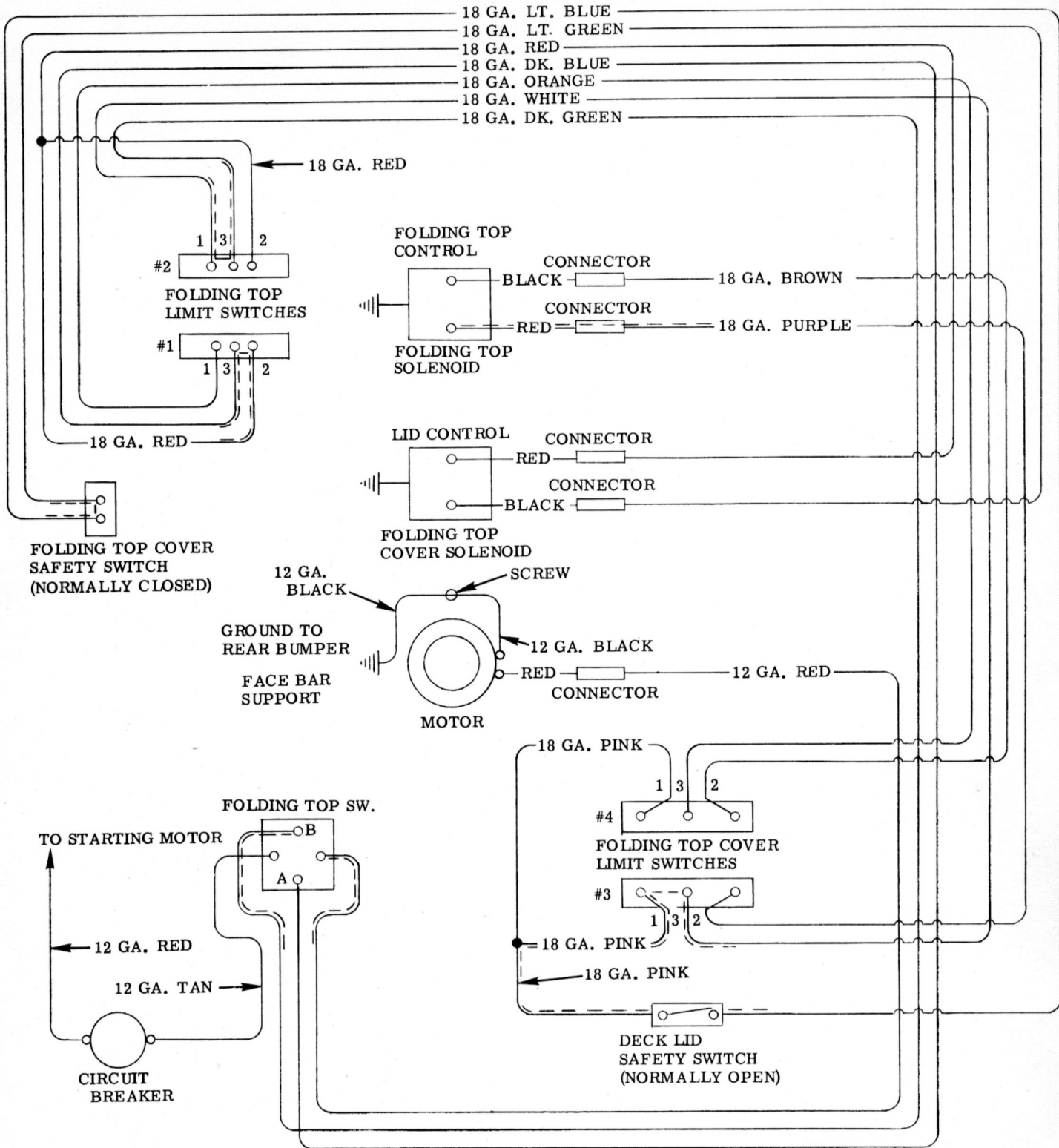

TOP IS IN HEADER POSITION WHEN SWITCH IS CLOSED. TO LOWER TOP CIRCUITS MARKED THUS - - - ARE ENERGIZED.

FOLDING TOP WIRING DIAGRAM

					NAME					CORVETTE INSTRUCTION MANUAL				
					REF.		DRAWN O. W.		CHECKED L. S.		SECT.		SHEET	
					DATE '9-15-55		PART No.		3726900		12		16.00	
DATE	SYM.	REVISION RECORD			AUTH.	DR.	CK.							